

The Magic of Ecology



Written by Steve Trash®

Published by Steve Trash Enterprises,
975 Old Dirt Road, Spruce Pine, AL 35585.

Steve TRASH® is a Registered Trademark
Young Eco-Hero® is a Registered Trademark

Cover Design and Illustration: Dianne Richerson, Steve Trash

Technical Illustration & Layout: Dianne Richerson

Editing: Steve Trash and his "Mom" Betty Richerson

Cover Photography: Patrick Hood

ISBN 0-9652542-2-4
ISBN 978-0-9652542-2-9

Second Edition

COPYRIGHT ©2005 by Steve Trash®

All rights reserved. No portion of this book may be reproduced- mechanically, electronically, or by any other means, including photocopying, transcription by Tibetan monks, or by smoke signals from extremely clever fish - without written permission of the publisher.

Steve Trash Enterprises • First Printing 1996

The Table of Contents

Steve Trash “Hello” letter	3
Some Things You Need To Know About Magic	4
Food Chain of Rubber Bands	6
Respect the Environment	9
CO ₂ to O ₂ Transformation	12
Anti-Gravity Water	15
Garbage to Pennies	17
Respect for People	19
Web of Life	22
Respect Yourself.....	25
The Forest Trick.....	27
Disappearing Bug	30
Earth is a Wild Place!	32
Some of Mother Nature’s Eco-Principles	34
The Web Spin	35
Vanishing Garbage	37
Recycled Pencil Transformation	40
Vanishing Silver Pebble.....	42
Linking Paper Clips	46
Water in the Boot	49
Magic Wand From Coin Purse.....	51
Greenhouse Penetration	53
Green Milk	56
Sun Fun	60
Water Planet Cards	62
Carbon Creatures	65
Renewable Resources	68
Dinosaur Water	70
Oil in Water	73
Glossary of Words	75
Good Bye	79



Hi! I'm Steve Trash. I've traveled all over the planet (Japan, Australia, England, Canada, and even above the arctic circle) performing magic tricks and making people laugh. I've noticed something in my travels. People around the world are working to make the world a better place to live. They're recycling. They're planting and taking care of trees. They're conserving resources. They're really getting smart about ecology and the environment.

All this stuff is really cool, but it's not EVERYTHING that we need to do to make the world a better place to live.

You see, to respect the environment means that you respect everything in the environment. That means you respect people, too. To respect people means that you must respect yourself as well!

Throughout *The Magic Of Ecology* you'll find tips for respecting yourself, others and the environment. Enjoy!

This book is filled with magic tricks that illustrate science ideas or principles. Do not get them confused. Science is about revealing truthfully how the physical world works. Magic is about artfully creating the illusion that you can defy physical laws of nature. You can't, but magic makes it look like you can.

I like to call kids who are working to make the world better Young Eco-Heroes.

The Steve Trash[®] Pledge

I, _____, being a really cool person,
promise to respect; myself, others and the environment.

The great thing about taking the Steve Trash[®] pledge is that you don't have to pay any money to get started. You just have to start making the world a better place to live. Remember that doing good feels good and can be a lot of fun. So, go for it. The world needs your help!

You + Other Young Eco-Heroes = Better World!

Your friend,
Steve Trash[®]

Illusionist ☆ Eco-Entertainer ☆ Kid Comedian ☆ Rockin' Eco-Hero

Some things you need to know about magic before you get started...

- ☆ TIP #1 - The tricks in this book are not that hard to do, but you will need to practice them. Remember, anything worth doing is worth doing well. Each trick has a rating.
- ♠ (one magic hat) means that the trick is easy to perform.
- ♠♠ (two magic hats) is a little harder.
- ♠♠♠ (three magic hats) is the hardest.
- No trick in this book is really hard to do. Have fun!

- ☆ TIP #2 - Nobody is ever great the first time they try something. So stay at it. Keep trying. You will get better.

- ☆ TIP #3 - Practice in front of a mirror. It gives you a good idea of how the trick looks to your audience. Remember—we're creating illusions. It's what the audience thinks you're doing that's important. So practice your tricks in front of a mirror, and then perform them for real people.

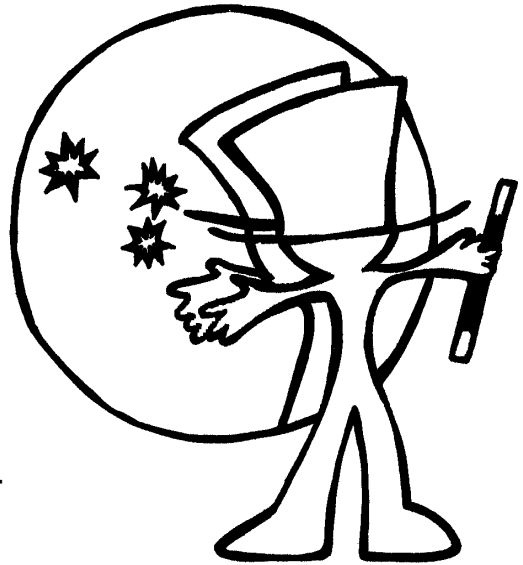

- ☆ TIP #4 - Don't just learn the trick and run out and show it to someone. Give it 5 or 6 rehearsals before you try it in front of an audience. It will be better, I promise. You'll thank me for this advice!

☆ **TIP #5** - Don't tell people how these tricks are done. Wait just a minute, Steve TRASH. Isn't this a magic book? Aren't you going to tell us **HOW** the tricks are done? Actually, no, I'm not. **I'm going to teach you how to DO magic tricks.** There's a big difference. Telling the secrets only destroys the mystery that makes magic fun. Teaching magic, however, gives a person the ability to perform it for themselves. See the difference?

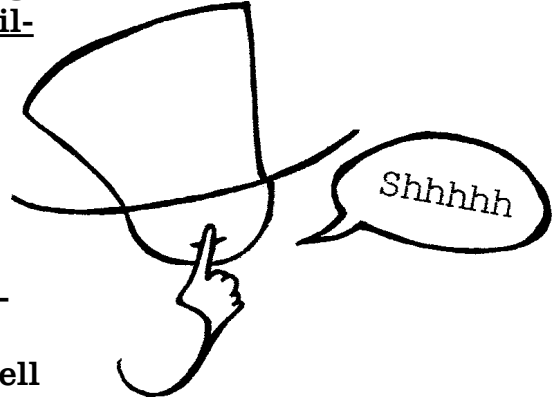

☆ **TIP # 6** - When performing don't be nervous. Relax and have some fun

☆ **TIP #7** - A good magic performance is very similar to good story telling. You must try to tell an interesting story with your magic tricks. Most of these tricks have good ecological stories already. Congratulations you're half way there!

☆ **TIP #8** - Borrow the things you'll need for your tricks, but be sure to ask permission first! Treat other people's things the way you'd like yours to be treated.

☆ **TIP #9** - Sometimes magicians have to make secret things that the audience never even sees. These secret things are called GIMMICKS. Watch for this word sprinkled throughout this book. Other times magicians have to make ordinary things do special jobs. These things are called GAFFS. Watch for this word too.

☆ **TIP #10** - Don't EVER tell your audience what you're going to do before you do it. They'll know what to look for and that makes it harder to fool them.

☆ **TIP #11** - Put some STP in your show - Showmanship, Technique and Personality. Showmanship means you make it exciting. Technique means you do it well. Personality means you allow your real self to shine through.

Food Chain of Rubber Bands

Imagine a little grasshopper munching on the leaf of a raspberry bush. He's minding his own business when along comes a spider and the spider eats him. Then a bird comes along and eats the spider. Then a snake eats the bird. The actors in this sordid tale - the raspberry bush, the grasshopper, the spider, the bird, and the snake - are all connected to each other through a food chain. They each share the need for energy to live. They get that energy from each other. When these creatures die, their bodies return to the soil as nutrients for plants. Then the whole food chain process starts over again.

Here's a wonderful magic trick you can do that will illustrate a simple food chain.

The Effect

Five separate rubber bands are dropped into a paper bag and magically link to each other just like a food chain.

What You Need

- ten rubber bands
- two paper bags (the brown "lunch bag" type is perfect)
- a pair of scissors
- some rubber cement
- a table

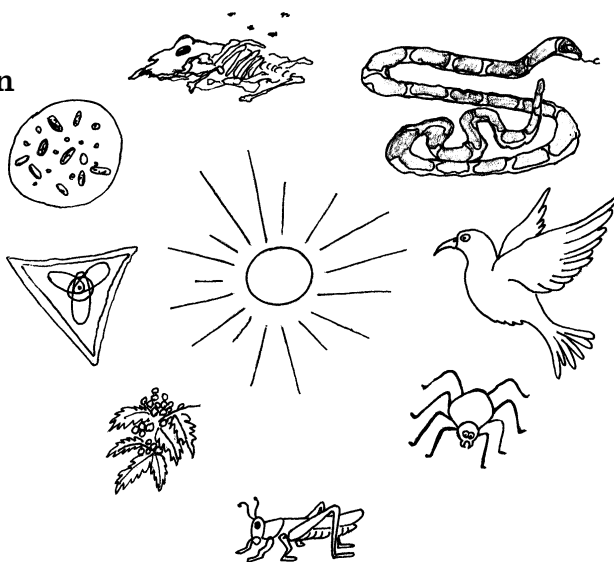

Secret Set-Up

You've got to make a **DOUBLE WALLED** paper bag. Here's how you do it.

1. Cut the first paper bag along the dotted line. (See illustration 1)
2. Put the big leftover piece (A) in your recycling bin. You won't need it anymore.
3. Glue the smaller piece into the second paper bag along the sides and bottom. **DO NOT** glue the top. Use rubber cement or white school glue. (See illustration 2 and 3)
4. This makes the secret compartment.

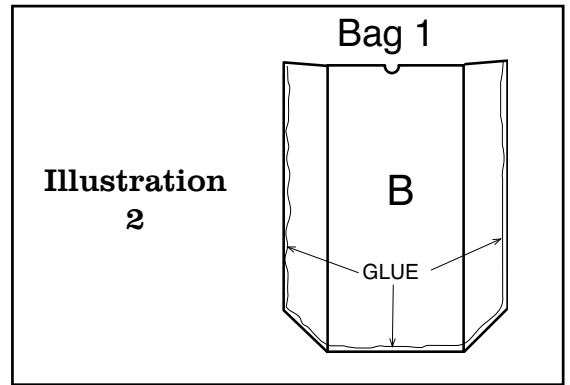
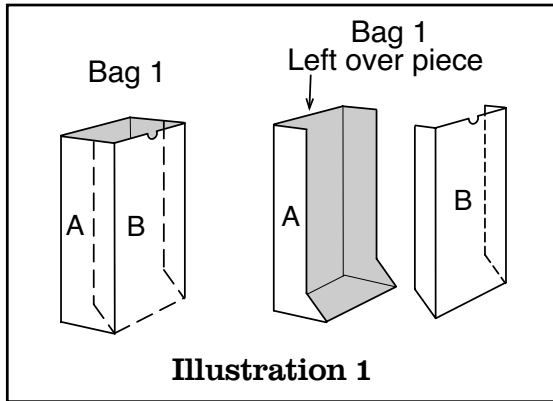

5. Let this sit until it's completely dry.

You've ALSO got to link the rubber bands into a chain.

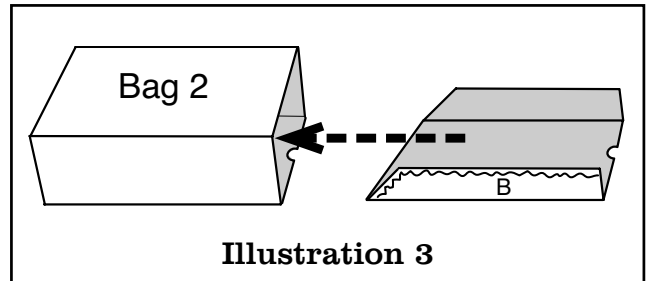

1. Cut four of the rubber bands with your scissors.

2. Put a little rubber cement on each of the cut ends. (See illustration 4)

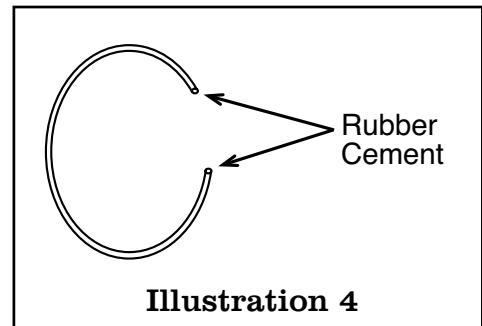

3. Let them sit until they are dry (three to five minutes). Don't let the ends touch each other yet.

4. Carefully loop the first cut rubber band through the uncut rubber band.

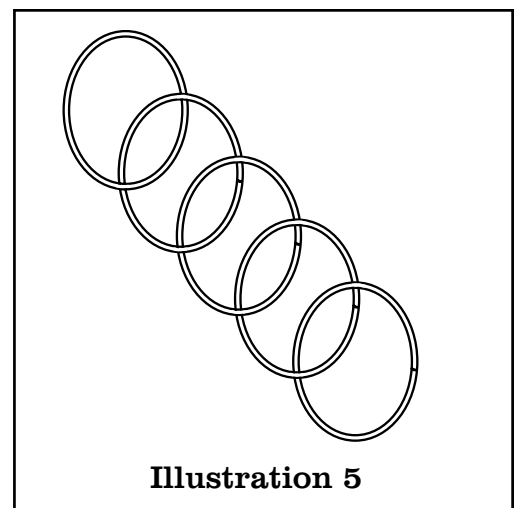

5. Touch the cut ends to each other, and they will stick. If you're careful, you won't even be able to tell that the rubber band has ever been cut. (See illustration 5)

6. Repeat this gluing until you have five linked rubber bands that make a nice chain.

7. Now put the rubber band chain in the **main** compartment of the paper bag, NOT the secret compartment. (See illustration 6)

8. Set the **Double Walled** paper bag, with the rubber band chain inside, on your table.

9. Now you're ready to rock and roll.

Showtime

1. Show the five separate rubber bands.

2. Let people look at each one. Collect them in your left hand.

3. Drop them one at a time into the secret compartment of the **Double Walled** paper bag with your right hand. (See illustration 7) Count them as you do this.

4. Tell the audience about the importance of food chains AND how each rubberband represents a piece of one food chain.

5. Now, dramatically pull the linked chain out of the main compartment of the bag. Say, "All of the pieces of a food chain are connected to each other through their shared need for energy."

6. Set the chain down on the table.

7. Hold the top of the bag with your left hand and tear it in half. (See illustration 8) It will

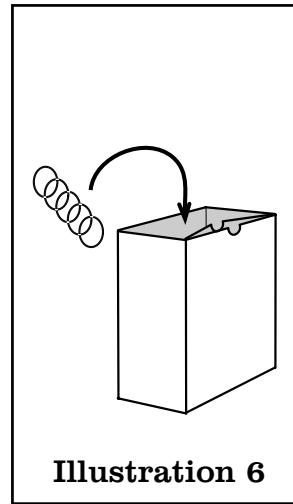

Illustration 6

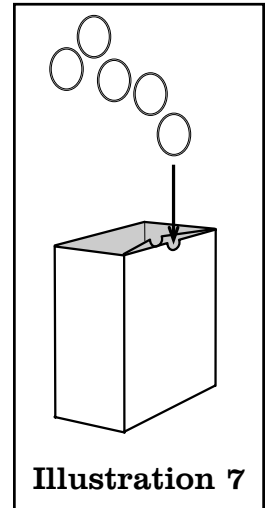

Illustration 7

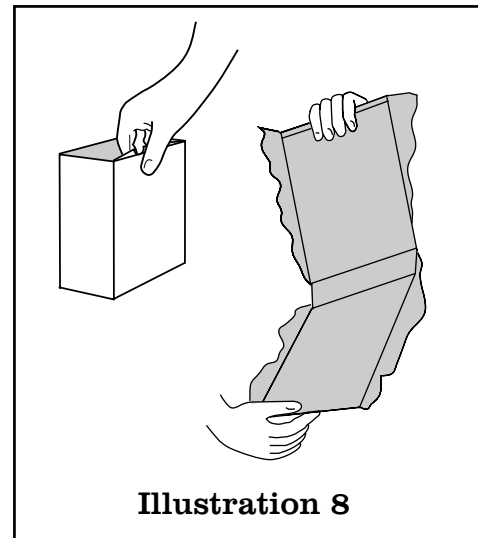

Illustration 8

tear along the seam of the secret compartment.

8. Show the pieces. There appear to be no other rubber bands. (They're hidden in the walls.)

9. You've magically linked the separate pieces of a food chain.

Respect the Environment



•Reduce, Reuse, and Recycle your garbage.

These are the magic words for making your garbage disappear. They're sometimes called the **3-R's**. Try to **REDUCE** the garbage you make in the first place. Think before you buy something. How much garbage will it create? You also need to **REUSE** things. Try to reuse old boxes, clothes, and toys. Reusing things uses even less energy than recycling. After you've reduced and reused then ... **RECYCLE** all the garbage that is left over. You'll be amazed by the amount of trash you can recycle. All of these things are recyclable: newspaper, writing paper, aluminum cans, glass bottles, plastic milk jugs, plastic bags, steel cans, and even motor oil.

•Buy recycled stuff.

Recycled products look exactly like non-recycled products. You have to look carefully for the recycled content label on the box. This label lets you know that the product is made with materials that have been re-

cycled. Recycling only works when you **BUY** recycled products! Otherwise, recyclable stuff ends up going straight to the landfill. Many of the following recycled products can be found in a store in your neighborhood (notebook paper, index cards, stationery, birthday cards, computer paper, recycled pencils, cereal boxes, and even flashlights). Look for the recycled label and buy that product.

•Avoid throwaway things!

Disposable or throwaway cups, forks, plates, and napkins are made to be used only once and then thrown away. That's not necessarily the best use of our natural resources. When possible, try to use reusable cups, forks, plates, and cloth napkins in place of disposables. (My family recently had a very big party. There were over 140 people at this party, and we used reusable forks, plates, and cloth napkins. When the party was over there was **VERY LITTLE** garbage because we'd used no throwaways at all.)

•Use reusable things.

Why not take a lunch box instead of a paper sack to school? Why not use a cloth napkin instead of a throwaway paper one? Why not use a reusable airtight plastic container instead of a throwaway plastic bag? These are REUSABLE things. Try it. You'll like it.

•Don't take a bag...

If you only buy one or two items at the store, don't take a bag. Who needs it anyway? It just clutters up the car and wastes resources.

•Recycle!

Collect your own recyclables at home, at school, or in your classroom; then recycle them. Find out if your school recycles.

•Use rechargeable batteries.

Do you use batteries? Most people do. If you use a Gameboy, a flashlight, or a calculator, you probably use **LOTS** of batteries. Rechargeable batteries are slightly more expensive, but they last **100** times longer than disposable batteries. That means you throw away fewer batteries. That means you'll be saving the environment, and you'll be saving money, too.

•Buy recycled stuff.

I know I've already mentioned this one, but it's really, really important.

•Educate yourself.

Read books about the world around you. It's really an amazing story!

The library is full of books on all kinds of fascinating subjects. The best thing is that the books are free **AND** they're being used over and over again. Go get a library card and check out a recycled book today.

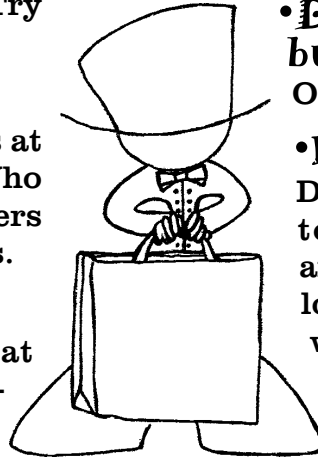

•Did i mention... buy recycled?

Oh yeah. I guess I did.

•Pass it on...

Drop off old clothes, toys, books, games and magazines at your local thrift store (Salvation Army Store, Goodwill, or a local children's hospital).

Somebody else will love to have your old stuff. By the way, while you're there shop around. One of my favorite things to do is shop for toys, hats, clothes, basketballs, dishes, magazines, and books at thrift stores. They're never expensive either. I recently bought a copy of the "Batman" book for 27 cents. What a deal.



•Don't be an Eco-finger pointer!

Remember, you and I will never know **EVERYTHING** there is to know about our environment (or anything else for that matter). So, help others to take care of the environment. But **BE PATIENT** and understanding with them. Remember the old saying: "You can catch more flies with honey than you can with vinegar").



•Take the "Steve Trash Pledge" and live by it!

"The Steve Trash Pledge"

I, _____, being a really cool person, promise to respect myself, others and the environment.

CO₂ to O₂ Transformation

Did you know the leaves of trees absorb **CARBON DIOXIDE** (CO₂) and release **OXYGEN** (O₂). It's one of the many **AMAZING** things that makes life on earth possible. We all work together to keep life on earth going. Even breathing helps. We breathe out CO₂ (Carbon Dioxide) every time we exhale. Trees and other green plants breathe in CO₂. So they take the CO₂ out of the surrounding air. They're so happy that they thank us by releasing fresh Oxygen (O₂). Our bodies can't live without fresh oxygen, so it's a great partnership. These kinds of partnerships run throughout nature. Here's a great magic trick that illustrates this. Check it out.



The Effect

A ping pong ball is shown to the audience. With a **BLUE** crayon you write the symbol for carbon-dioxide (CO₂) on it. Then you wrap the ball in a large green scarf that is cut in the shape of a maple leaf. Each person in your audience is allowed to reach beneath the cloth to feel the ball and make sure it's still there. Everyone says, "Yes it is." You hand the bundled leaf and ball to someone in the audience and they open it. The symbol for oxygen (O₂) is now written on the ping pong ball. It has magically transformed from CO₂ to O₂. Just like the natural world!

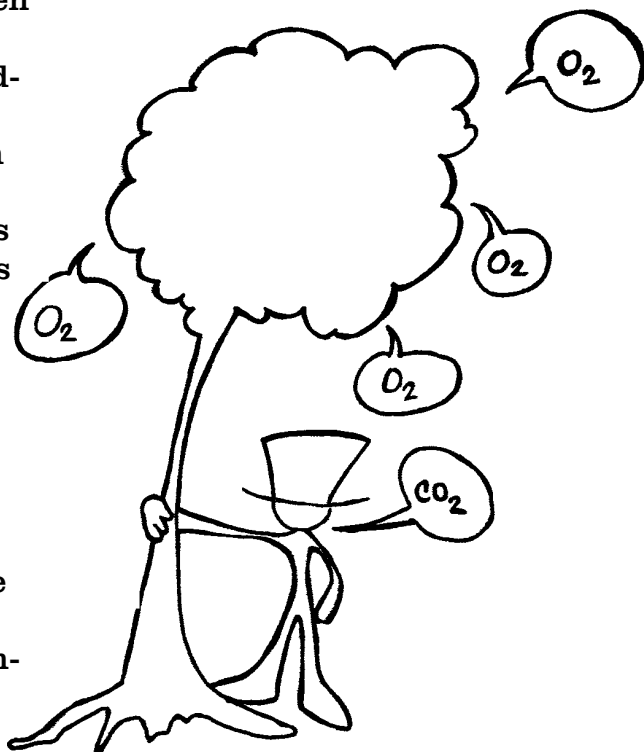

What You Need

- two ping-pong balls (Any small balls that look alike will do.)
- a blue crayon
- a green piece of cloth cut into the shape of a maple leaf (approximately 18" x 18")
- a secret helper

What You Need To Make

1. Take your blue crayon and write O_2 on one of the ping-pong balls.
2. Cut a piece of green cloth into the shape of a leaf. You don't have to be exact. Just make it look kinda like a leaf. (See the illustration 1)

Secret Set-Up

1. Find a friend who will be your secret helper. She actually switches the balls FOR you.
2. Rehearse switching the balls with your secret helper. Have her reach under the cloth. She switches the ball she is **SECRETLY** holding for the one you are holding. Do this under cover of the leaf shaped cloth (See illustration 2). She must pretend that she's just reaching in to feel the ball and nothing more. The whole illusion depends on this.
3. Once you've rehearsed the switch, you're ready to get on with the show.
4. Have your secret helper hide the ball with the blue O_2 in his or her hand. Don't worry no one will suspect.

Showtime

1. Show the blank ping-pong ball to everyone.

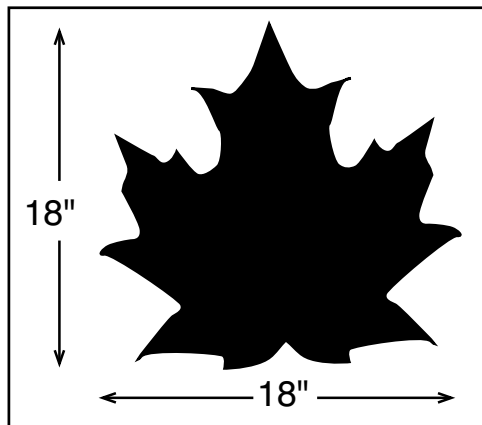
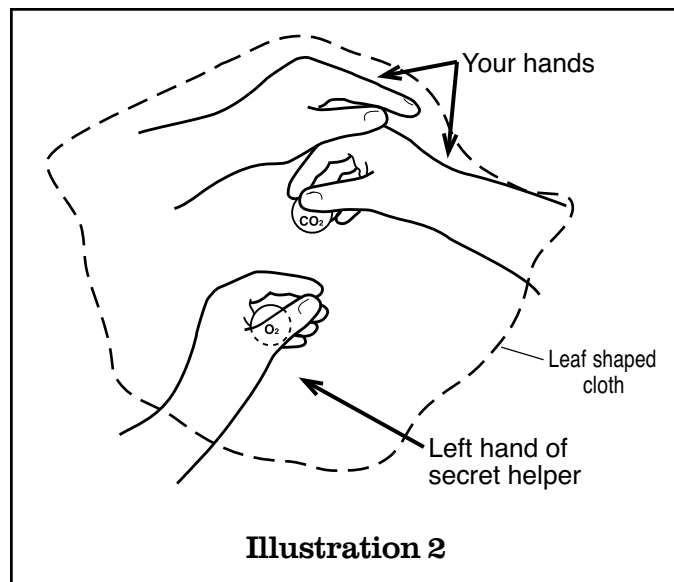

Illustration 1

2. Draw the letters CO_2 on with the blue crayon. Draw the letters about the same size as the blue O_2 letters you drew on the **OTHER** ping-pong ball.
3. Drape the green leaf shaped cloth over both your hands. Hold the blue CO_2 ball in your right hand while cupping your left hand on top. (See illustration 2) Now you are in position to trade your ball with the one your secret helper is holding.
4. Ask the first person (not your secret helper) to reach under the cloth and feel the ball. Ask them if the CO_2 ball is still there. When they say "yes", move to the next person.
5. Ask three or four people to reach under the cloth and feel the ball. Ask them all if the CO_2 ball is still there.
6. When you reach your secret helper, have her reach under

- the cloth like everyone else. Have her secretly switch the ball she is holding for the one you are holding. Do this under cover of the leaf shaped cloth. Try to do this at about the same speed you did with everyone else. Ask her if it is still there? She says "yes."
7. Move back to the center of the room. Everyone still believes that you are holding the CO_2 Ball. (But you're not ... hee, hee, hee!)
 8. When all the attention is back on you, your secret helper puts the extra ball in her pocket.
 9. Now you've got to really ham it up. Say, "Trees and green plants absorb the Carbon Dioxide that people exhale. They transform that CO_2 into oxygen for us to breath. Watch."
 10. Roll the cloth into a bundle around the ball.
 11. Give the bundle to someone to hold (not your secret helper). If possible, give it to someone sitting away from your helper. Pass your hands over the bundle two or three times and say, "The Carbon Dioxide CO_2 has now become O_2 Oxygen. Check it out."
 12. When he opens the bundle, he'll be totally stunned. The ball has been magically transformed. It's sort of like the magic of mother nature.



Anti-Gravity Water

The natural world is very mysterious. People have always tried to create theories that explain why things happen. You can do this, too. You can make observations, create theories, and test them. This is called the "scientific method." Here's how it works:

1. Make an observation about the world.
2. Create a theory that might explain the observation.
3. Create an experiment to test this theory.
4. Draw a conclusion about the accuracy of your theory.

Sometimes things that happen in nature seem to defy natural laws, but that's not possible. Here's a great example. Water stays in a glass that's turned upside down. It looks like MAGIC, but it's really physical SCIENCE at work. Can you create a theory that explains why it doesn't fall out?



The Effect

A postcard is placed over the mouth of a glass of water. It is turned upside down, and no water comes out.

What You Need

- picture postcard
- glass
- water
- towel (to clean up any mess you might make)

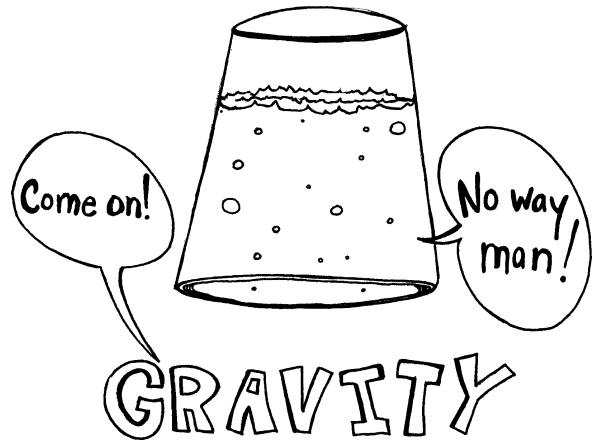

Secret Set-Up

Fill the glass with water.

Showtime

1. Show the glass of water.
2. Place the postcard over the mouth of the glass with your left hand. (See illustration 1)
3. Hold the postcard against the mouth of the glass with your left hand.
4. Pick up the glass with your right hand.

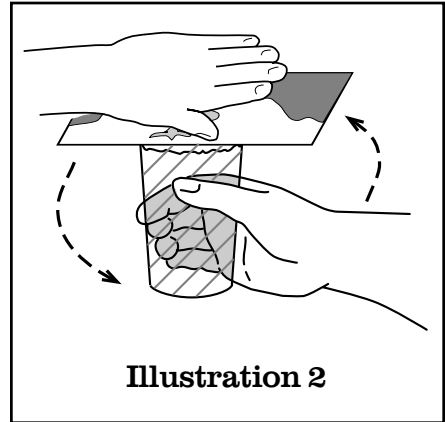
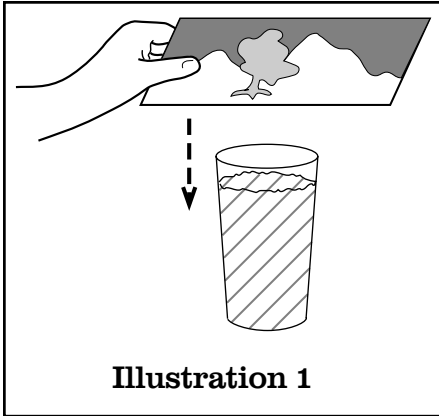

5. Slowly turn the glass over and hold the postcard tightly against it with your left hand. (See illustration 2)
6. The postcard will stick to the mouth of the glass, and the water will remain inside. It looks magic, but it's really science. (See illustration 3)
7. Hold the post card against the mouth of the glass with your hand. Turn the glass upright again and slide the post card off. Science rules!

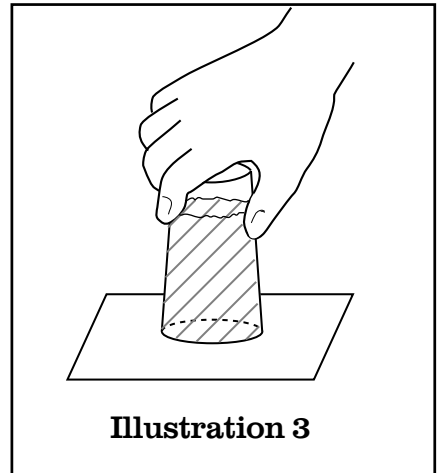

Garbage to Pennies

Garbage is a natural resource. All natural resources are valuable.



The Effect

A soup can full of garbage is transformed into a whole lot of pennies.

What You Need

- two empty metal soup cans (that look exactly alike)
- 50-100 pennies
- shredded paper and assorted small garbage
- thick corrugated cardboard
- black poster board
- scissors
- white glue
- dinner plate
- cloth handkerchief or bandanna

What You Need To Make

1. Cut disk #1 out of the poster board. Trace the outside of the can to get the size exactly right. (See illustration 1)
2. Now cut the corrugated cardboard in a circle just slightly smaller than the poster board circle. This disk should be able to fit into the can very easily. (See illustration 2)
3. Glue the two disks together and allow them to dry completely. (See illustration 2)

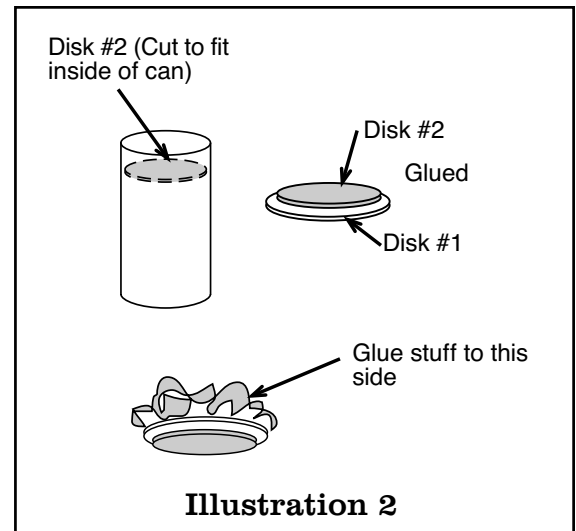
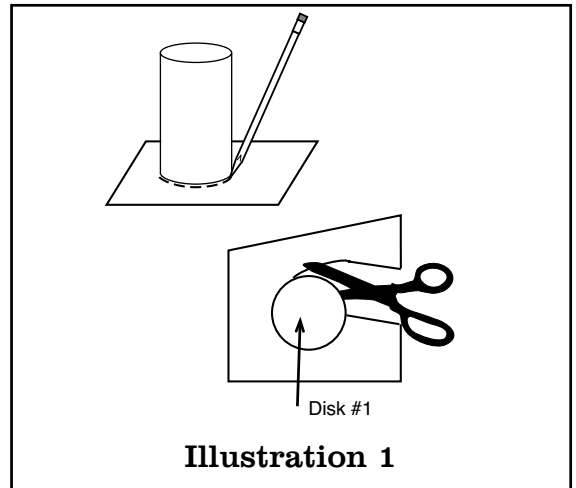

4. Glue some shredded paper and other small pieces of garbage to the poster board side of the disk. (See illustration 2)
5. Fill one of the cans with pennies almost to the top.
6. Place the disk on top of this can. Leave the other can empty.

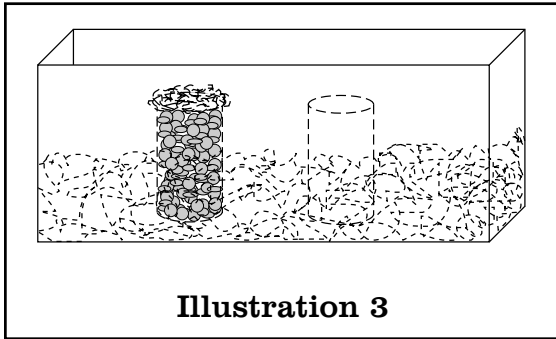

Illustration 3

Secret Set-Up

1. Put both the metal cans into your cardboard box filled with small garbage. (See illustration 3).
2. One can has the 50 - 100 pennies, and the disk is placed on top.
3. The other can has nothing at all in it.
4. Set the bandanna on the table.
5. Set the box on the table.
6. Set the plate on the table.

Showtime

1. Lift the first can out of the box and show that it's empty. Say, "This box is full of garbage."
2. Dip the empty can into the box and scoop out some of the garbage.
3. Hold this can up and show that it's now FULL of garbage.
4. Pour the garbage back into the box slowly.
5. Reach back into the box with the can and pretend to scoop

out a second batch of garbage. Actually you LEAVE the empty can and PICK-UP the gimmicked can with the garbage disk on top.

6. Hold it up in the air like you did the first time.
7. Brush some of the garbage off the top of the disk. Say, "Garbage". It will appear that you have a can that is completely full of garbage.
8. Cover the can with the cloth.
9. Now say, "Garbage is a natural resource. Natural resources are valuable. Garbage is valuable."
10. As you are pulling the cloth off the can, secretly grab the edge of the disk and pull it away too.
11. Casually drop the cloth and the hidden garbage disk into the cardboard box.
12. Pour the pennies out of the can onto the plate and show the transformation. Garbage IS valuable!

Respect Others

• **Treat other people like you'd like to be treated yourself.**

This is sometimes called the "golden rule." Treat others the way you would want them to treat you. In just about everything we do, this is the best guideline to follow. So, here's how you do it. When you don't know how to treat someone, imagine that you are in that person's situation. Ask yourself how you'd like to be treated. Then, whatever the answer is ... **DO IT.** Use the golden rule as a measuring stick to check out your daily actions.

• **Be helpful to other people.**

Look for ways to be helpful. If you're really good in a particular subject at school, then help somebody else in your class with their homework. (Don't do it for them. That wouldn't be helping; that would be cheating. It won't do either of you any good.) Help your mom with the groceries. Help wash the dishes. Help wash your dog. If you don't have a dog,

then wash your fish. (Nope, sorry, he's probably clean enough.)

Remember... the help that you give someone is really important to that person, **BUT** it is even **MORE** important to **YOU**. When you do good for others, you're also doing good for yourself. You become a better person every time you help others. That's a key to making the world a better place to live. (Oh yeah, the best way to help others is to do so willingly without pay or reward. You can work for pay, but don't take money for just being helpful.)

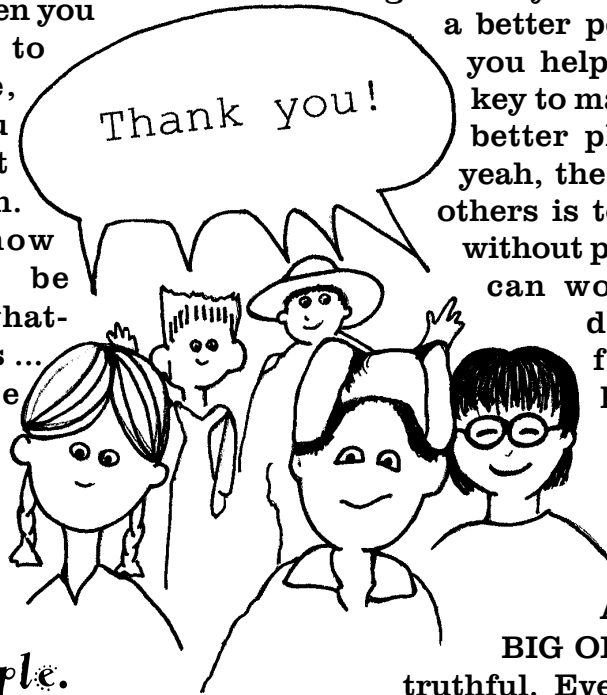

• **Tell the truth.**

Here's a **REALLY REALLY BIG ONE!** Don't lie. Be truthful. Even when you mess something up really badly. If you tell the truth, people will trust you, and they will learn to depend on you. As a bonus, people who tell the truth also trust themselves to do exactly what they say they will do. This builds self-confidence and self-esteem. Anyone can slip up and make a mistake (and you will), but keep trying to be honest.

•Be respectful.

Being respectful means being courteous and polite. It's how you show others they are valuable. Be respectful to your teachers, your parents, and your friends. There are lots of different kinds of people in the world. Being respectful and having good manners will make it easier for the whole world to get along.

•Be kind to all

animals and take good care of them. Don't hurt or kill harmless creatures without reason. The world is full of people that do bad stuff. There is no reason to add more bad deeds to the mix. Many creatures are so helpless that they can't even defend themselves. Because we are strong, it is always our responsibility to protect the weak and help them when we can. Don't ever hurt or kill unless it's for your own biological survival (food, clothing, or shelter). If you are a hunter, then take full responsibility for your actions. Respectfully use everything that the animal's body gives you (the meat, the hide, the bones, etc). If you don't use everything, you're being wasteful, and it's disrespectful to the animal whose life you've taken.

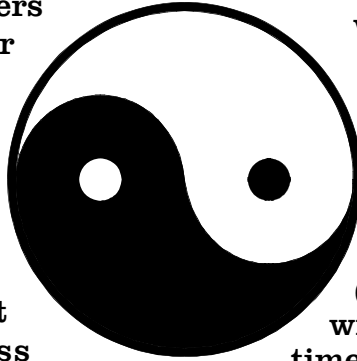

•Obey rules and laws.

There are lots of rules and laws. If you think the rules or laws you have to obey are unfair or wrong, then write letters and lobby your lawmakers to have them changed.

•Be thrifty.

This is a really old fashioned word, but it's very important. Thrifty people do not waste.

- (1) Thrifty people use the earth's natural resources wisely.
- (2) They use their time wisely. (They don't waste time watching stupid TV shows like they're a bunch of big fat hairy couch potatoes.)
- (3) They use their property wisely. (They take care of their toys, their room, and things people lend them.)
- (4) They work to pay their own way and to help others do the same. Many thrifty people shop at thrift stores.

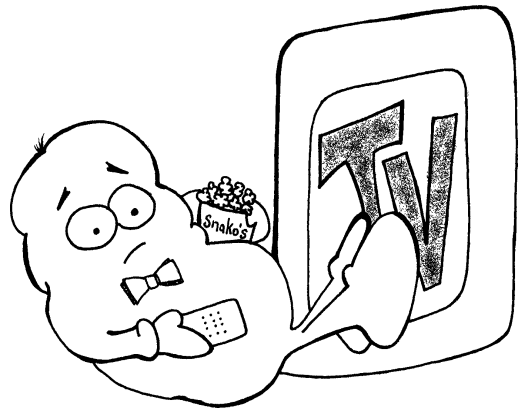

•Be friendly.

It really doesn't take a lot of effort to be friendly. Smile at other people. Try to get to know them. Say, "Hello." Getting to know other people can be fun, and it may show you how interesting other people are. People without friends are usually only interested in themselves. Being friendly is essentially accepting another person as he or she is, not as you think he or she should be. Try to make some new friends at school.

•Be Brave, but don't ever take foolish chances.

Stand up for what you believe is right. When others laugh at or threaten you for not stealing, or not lying, or not using drugs, stand tall and be brave. Don't do it! Now I know some people who believe being brave means that you're never afraid. No way... that's not it at all. It means that you will stand up for what is right even when you are afraid. Everyone can become afraid. Be brave and strong, and don't ever take foolish chances!

•Be a Peace Builder.

This is a tough one. When you are in an argument or in conflict with somebody, do everything you can to resolve the conflict without violence. Walk away if you can. Diffuse the situation. The world needs less violence!

•Don't take things that aren't yours.

If you ever consider taking something from someone else, then think about this. If someone stole something that was yours, let's say they took your... watch. How would you feel? I'll bet you'd feel pretty crummy. You might even get mad. Why would you feel mad? Because that person has no right to take something that is yours. They didn't work for it. They didn't earn it. They just wanted to take a short cut to getting what they wanted. People who take things that aren't theirs are lazy and selfish. They don't want to work and save to get those things. They want them right now. Unfortunately, by stealing they lose all of the personal pride that comes from owning something that you worked hard to get. Honesty and hard work carry their own rewards. Don't ever steal.

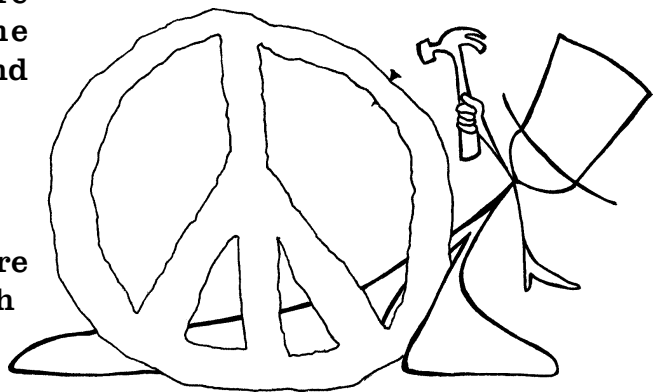

"WEB OF LIFE"

People are a part of the "Web of Life."
It sustains all life on Earth.

The web of life is a concept that illustrates how connected everything on earth is. Imagine a HUGE spider web with many different strands that interconnect and inter-relate to each other. Every kid in the world is a part of the web of life. Every animal is a part of the web of life. The plants, the trees, the air, the water, the weird little purple bugs that you've never heard of are all individual strands in the web of life. Each one makes his own little contribution to sustaining life on Earth.

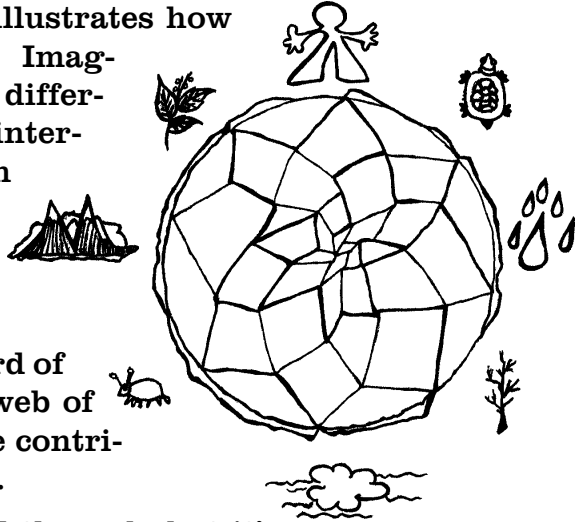

We can't see the web. We can't feel the web, but it's real. Because we are a part of the web of life, we need to take care of it.



The Effect

A string representing one strand in the "web of life" is cut with a pair of scissors. The cut pieces are trimmed off and they fall to the floor. The magician says, "Everything is connected in the web of life," and the string is made whole again.

What You Need

- a two foot long piece of string (thicker string will show up better)
- a secret loop of string (seven inches long)
- a pair of scissors

What You Need To Make

You need to make the Secret Loop of string.

1. Cut off a piece of string about seven inches long.
2. Put its two ends together.
3. Tie these two ends into a knot.
4. This should leave you with a tear drop shaped loop of string (The loop should be about two inches tall).
5. Cut off the two loose pieces of string that are now sticking out of the knot. You now have

a loop with a knot at the bottom. This is your **SECRET LOOP**. (See illustration 1)

Secret Set-Up

1. Before the show, put the **SECRET LOOP** in you left hand with your fingers loosely wrapped around it. (See illustration 2)

(A special note: Remember to hold your hand as naturally as possible. People will only be suspicious if you give them a reason to be.)

2. The middle of the two foot long string is held by your right hand. Now you're ready to go.

Showtime

1. Show the string with your right hand. Say, "The string represents one strand in the web of life."
2. Put the long string into your left hand and pull the Secret Loop up to the top of your left hand. This will look to the audience like it's the middle of the two foot long string. (See illustration 3)
3. Immediately pick up the scissors with your right hand and show them to the audience.
4. Take the scissors and cut the Secret Loop. It will look like

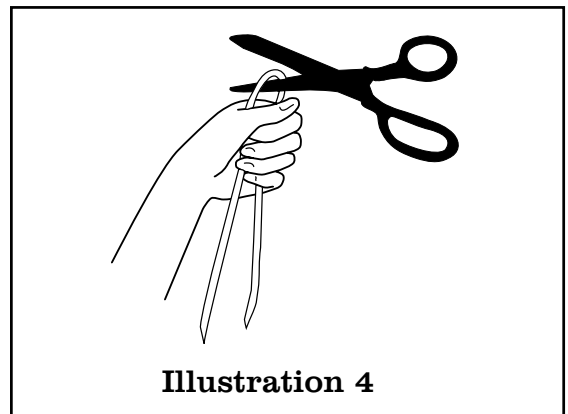
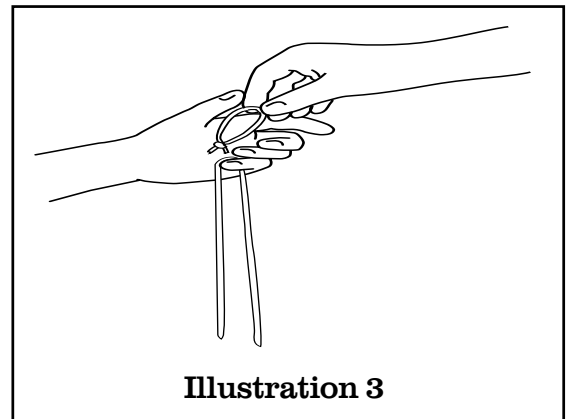
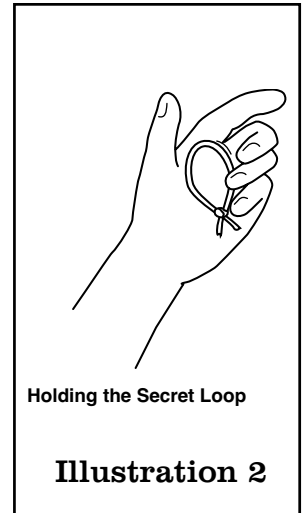
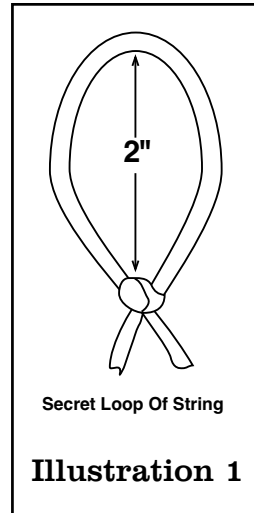

you've cut the string in half.
(see illustration 4)

5. Show this cut to the audience. Now clip two more pieces off

the **SECRET LOOP**. Let these pieces fall to the floor. Now pretend to clip the third piece of the string with your scissors, but really just let the knot and leftover **SECRET LOOP** piece fall to the floor. Don't cut the two foot piece of string!

6. Still holding the middle of the string say, "Everything is connected in the web of life."
7. Show the audience that the string is restored. (See illustration 5)

(This is a wonderful trick. I even use a version of it in my stage show.)

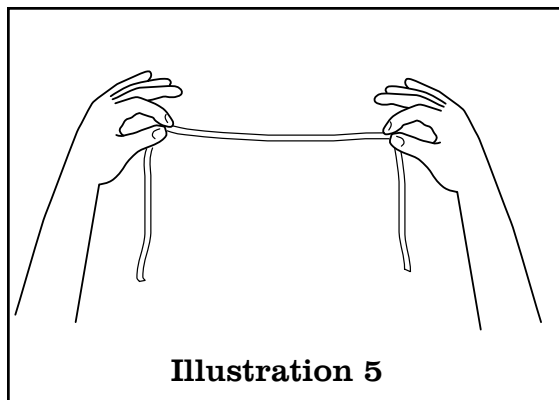

Respect Yourself

• **Eat food that's good for your body.** Food supplies the energy that our bodies need to breathe, sweat, heal, and sleep. Eating good food is the best way to stay healthy. Foods that are good for your body include: fruits and vegetables, whole grain breads, water, and milk. (Try to eat less junk food and candy. Too many candy bars and potato chips can rot out your teeth and make you sick.) When you choose to eat good food you'll grow stronger, feel better, and have lots of energy to do the exciting things you want to do!

• **Read a good book.** Reading may be hard for you. Believe me. I understand. When I was a kid it was **REALLY REALLY TOUGH** on me, but it **IS** worth the trouble. Because reading will open a whole new world to you. Any subject that you're interested in can be found in a good book. (Stuff about the Big Bang, Barbie & Ken, Gregorian chants, burps, or even magic tricks.) You name it, and you can read about it. What are you waiting for?

• **Be as neat and clean as you can.** You'll feel better, look better, and definitely smell better. Whoa!

• **Enjoy life. It's fun.** Smile. Have some fun. Enjoy life.

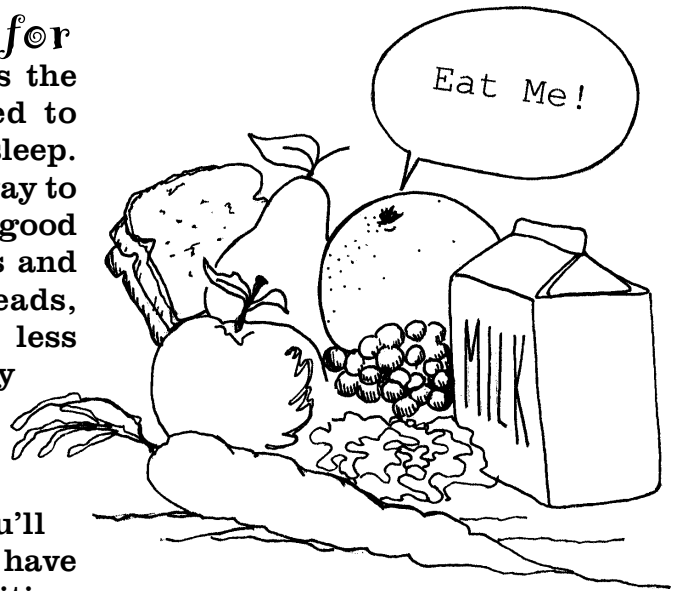

• **Be cheerful.** Look on the bright side of things. Smile. Be optimistic. (Here's an experiment I tried recently. Every time something difficult or challenging happened to me, I would think to myself, "Things usually work out for the best. So I'm going to do everything I possibly can to meet the challenge and then forget about it." It's been working so far. Try it.) Cheerfully do the jobs that you are asked to do. You create your moods. I know this sounds crazy, but it's true. You're happy because you've **decided** to be happy. You're sad because you've **decided** to be sad. You're grumpy because you've **decided** to be grumpy. So try to look on the bright side of things. You'll feel better. You'll even look better.

• **Study hard at school.**

I know this may be hard for you, but hear me out. Some of the subjects at school may not be that interesting to you (I thought Algebra II was totally the pits), but the subject isn't necessarily the important thing. What's important is using your **MIND**. Using your mind to solve challenges may even be more important than the subject you're studying. Here's why... as long as you live, you're going to face challenges and problems. (Things that aren't easy, but you must solve anyway.) If you've developed your mind, you'll be able to handle any problem that comes your way. Look at your tough school subjects as boot-camp for problem solving in the future.

• **Give yourself a hug.** You are special. No... really. I mean it. You are! **There is no one in the universe like you.** You have special talents. You have a special voice. You have special freckles. You have special ears. You have a special role for being on the earth at this time and at this place. So give yourself a big hug for being one of a kind. You are wonderful.

• **Do something great with your life.** Do you ever dream of being something great? Then chase that dream. Be a teacher, an ecologist, an artist, a garbage-man (I did... and my mom is sooo proud!) or whatever it is that you think you'd like to be. Remember that

your creator has something **wonderful** in mind for you and your life. Try to discover what it is and then go for it!

• **Get 8 hours of sleep every night.** Everyone's body needs time to grow, rebuild itself, and fight off disease. You'll feel better, work smarter, and have more fun if you get a good night's rest. I still try for eight hours of "snooze-time" every night!

• **Don't put anything in your body that will harm it.**

Smoking anything is bad for your lungs and your heart. Drinking lots of alcohol is bad for all parts of your body. Illegal drugs are **REALLY** bad for your body. In fact, they're just substitutes for "real" fun. They can even harm your spirit. Don't do anything to harm your body, your mind, or your spirit.

• **Run, skip, jump, hop, or walk around as fast as you can.**

It's great for your body, your mind, and your **spirit**. Remember, we are spiritual beings, having a human experience.

• **Take some private time** to pray, meditate, or just to be thankful for your many blessings. This is the key to living a balanced life. Find a quiet place to do this. Then, close your eyes and find the quiet place **inside** yourself.

The Forest Trick

The average American uses the equivalent of seven trees a year (for writing on, living in, sitting on, sleeping on, reading, staying warm with, hitching their horses up to). These trees come from forests. Forests have many uses.

☆ Forests can be used to provide lumber to build houses and furniture or to make paper.

☆ Forests can also be used to provide medicines to heal people who are very sick (treatments for cancers have been discovered in tropical rainforests).

☆ Forests can also be used as places to relax, clear your head, and get close to nature.

☆ Forests also provide homes (called habitats) for a wide variety of plants and animals. These habitats support the ecosystems that, in turn, support the web of life that, in turn, support us that, in turn, support the habitats ... well, you get the idea.

☆ Forests also provide some of the clean air we need to live.

When we make decisions about how to use forests, we must keep all the uses in balance, so that one doesn't harm the others. This is called forest management.



The Effect

A glass is balanced magically on the top edge of a playing card.

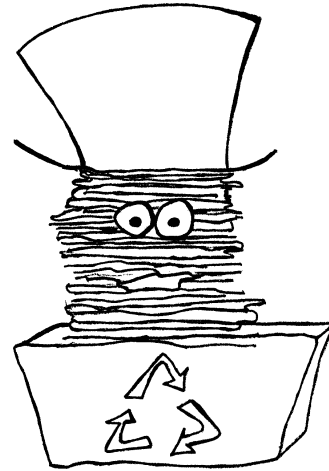

What You Need

- an old deck of cards
- wine, champagne, OR any glass with a stem
- glue
- leaves, bark, pine needles, twigs, or anything else you can think of to represent forests
- a heavy book

Secret Set-Up

1. Take two cards out of the deck.
2. Fold card #1 in half from side to side. (See illustration 1)

3. Now glue the front left side of the folded card #1 to the back left side of card #2. (See illustration 2) Try to match the edges of the cards carefully.

4. Place a heavy book on top of the cards to flatten them out. Let the cards dry completely.

5. Once dry, you have a card with a flap that opens and closes. (See illustration 3)

6. When closed it looks like a single playing card. This is your gimmicked card.

7. Put the leaves, bark, pine needles, etc. in the wine glass. Now you're ready to go.

Showtime

1. Show both sides of the GIMMICKED card. When it's folded flat it looks totally normal.

2. Put the card into your right hand with your left hand.

3. Allow the flap to come open.

4. Hold the flap open with your right hand. (See illustration 4)

5. Pick up the wine glass with your left hand. Say, "This glass symbolized our forests."

6. Set the wine glass on the gimmicked card in your right hand. (See illustration 5) Say, "Each way we use our forests must be in balance with the other ways we use them."

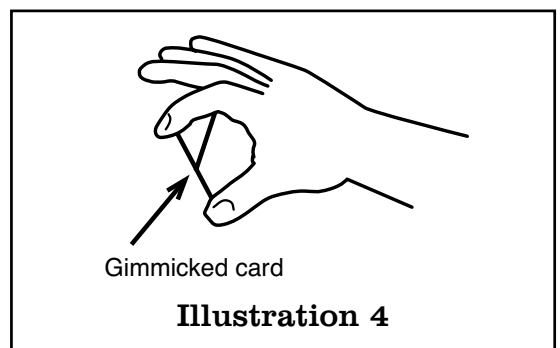
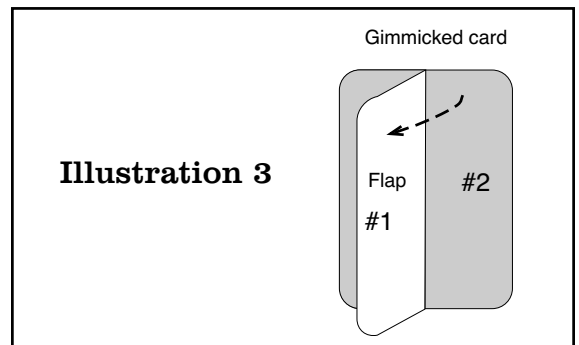
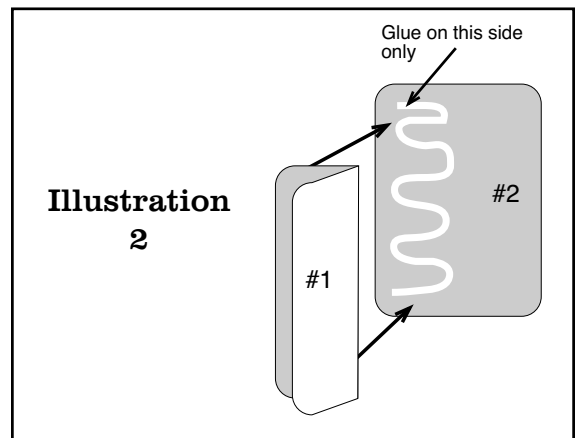
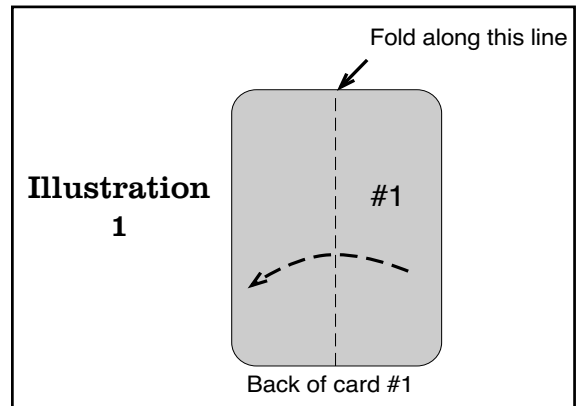

7. Draw your left hand away slowly from the balanced wine glass. The wine glass will appear to be balanced on the slender edge of a playing card. It's really balanced on the edge and the secret flap.
8. Lift the glass off with your left hand.
9. Immediately close the flap of the gimmicked playing card with your right thumb and first finger.
10. Show both sides of the gimmicked card again.
11. You've balanced the glass on the edge of a playing card.

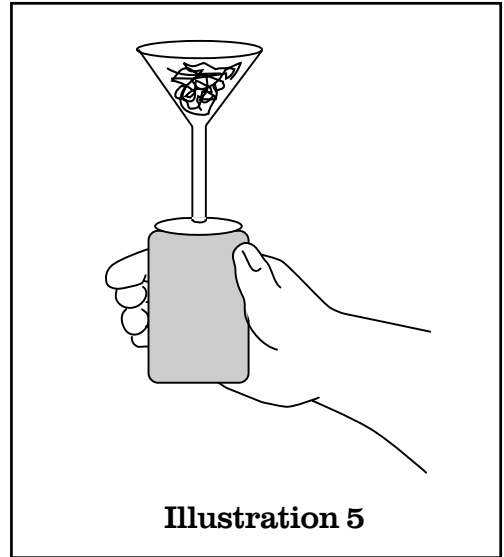

Disappearing Bug

Every species has a right to be here.

An ugly green bug has just as much right to be here as anything else. That bug might be doing something very important that you're unaware of. It may be eating mosquitos or pollinating flowers. Wiping out an entire species of anything is irresponsible. In fact, protecting the diversity of life on earth is a very important part of OUR survival. The more diverse any biological system is, the better it is able to adapt to changes. Take care of it an it will take care of you.



The Effect

You show a small picture of a bug.

The picture is wrapped in a newspaper and given to someone to hold. You wave your hands and say, "Good-bye,-Bug" and the bug has vanished forever.

What You Need

- a table to set the props on
- two sheets of newspaper
- white glue
- two pieces of stiff white cardboard (at least five inches by five inches)
- markers or crayons
- a magic wand (this can be any kind of stick, pencil, or even a pen)
- scissors

What You Need To Make

1. Draw or cut out a picture of a bug and glue it onto the first piece of cardboard.

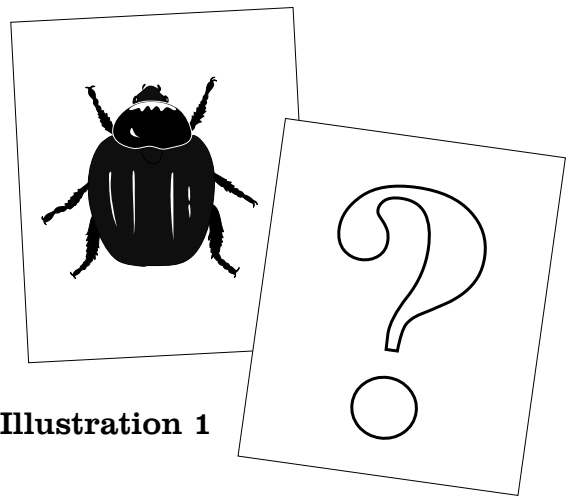

Illustration 1

2. Draw a question mark on the second piece of cardboard. (See illustration 1)
3. Take a full sheet of newspaper (one that folds in the middle from top to bottom) and lay it flat on the floor or on a table.
4. Starting at the bottom, cut it along the fold all the way to the top. This will leave you with two pieces of paper about twenty-two inches tall by fourteen inches wide.

5. Take a second sheet of newspaper and cut it into two pieces just like the first. You should now have four, twenty-two inch by fourteen inch sheets.

Secret Set-Up

1. Fold each twenty-two inch by fourteen inch sheet of newspaper in half.
2. Stack the four newspaper sheets on the table. The open ends should face you.
3. Lift up the top sheet of newspaper, then slide the question mark (?) picture in.
4. Count three sheets down from the top of the stack. Bend the front edge of these pages slightly upwards. (This will make it easier to pick up the right newspaper edge later.)

Showtime

1. With your right hand, show the piece of cardboard with the picture of the bug on it.
2. With your left thumb and fingers lift the top three pages in the stack of newspapers.
3. Slide the bug picture into the newspaper with your right hand. Put it under the third page from the top. (See illustration 2)
4. Immediately, grab the top folded piece of newspaper with

your left hand, leaving the bug picture in the newspaper still on the table. You've secretly gripped the hidden question mark picture.

5. Fold the newspaper around this picture and hand the whole package to someone in your audience.
6. Take your time on this part. The hard work is already done.
7. Wave your hands magically in the air and say, "Good bye bug."
8. Ask the person holding the picture to unwrap it.
9. Show everyone that the bug has magically disappeared.

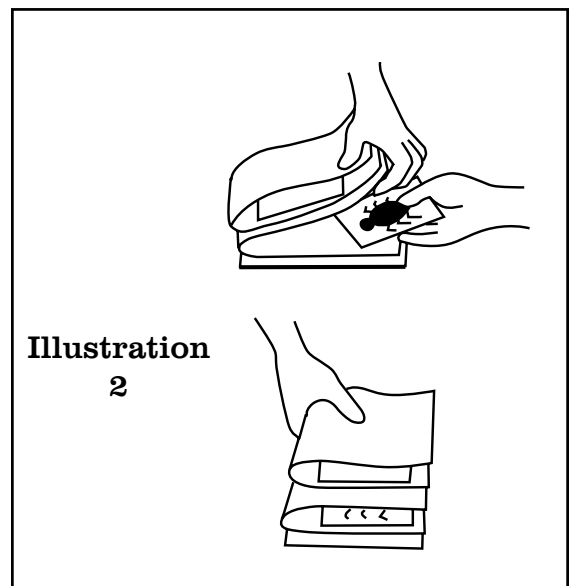

The Earth is a Wild Place!

As far as we know, it's like no other planet in the whole universe. What do you think makes it so special? Size? Nope, there are smaller planets, and there are bigger planets. It's really colorful? Nope, there are even more colorful planets in our own solar system. It's got a really funky name? Well, yeah, but that's not exactly what I was thinking of.

The earth provides everything you and I need to live: air, land, and water.

We absolutely cannot live without clean air, clean land, and clean water. Our bodies will die (you know... croak, cease to exist, hasta la vista baby, take the last train to DARKSVILLE ...get my drift?) without them. The planet Earth is like a "state of the art" **spaceship**. It has all the latest gadgets and gizmos, flashing lights, and hip TV game shows, but its most exciting feature is its life support system.

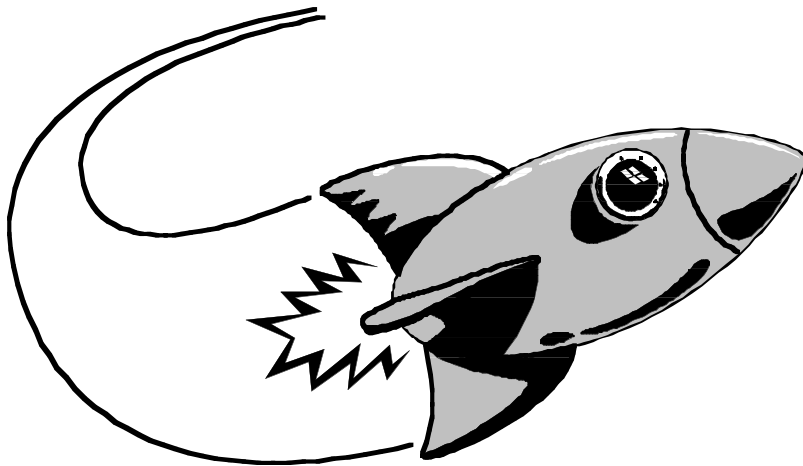

A LIFE SUPPORT SYSTEM IS ANY MACHINE THAT PRODUCES ESSENTIAL HUMAN NEEDS LIKE AIR, WATER, AND LAND.

Our life support system is called the Web of Life. We have clean air to breathe thanks to the web. We have clean water to drink, thanks to the web, and we have abundant food thanks to the web. If we start messing with the web of life by polluting, overusing resources, and over populating, we disturb nature's balance. Disturbing nature's balance is no trivial thing either because you and I are a part of the web. So what affects the web will affect all of us.

Holy Cow!

So what do we do? With so many people out there, how do we keep from totally messing up the web? Good question! Mother Nature is incredibly smart! She created the "web of life" with certain rules or principles that control and guide all life on earth.

(Mother Nature is not actually a he or a she.

It is an intelligent force that creates and regenerates life on the planet.)

If you and I violate these principles, we'll suffer the consequences.

(We'll get bodyslammed by Mother Nature, so to speak.)

Using these principles as a guide we can build our lives in greater harmony with nature.

**What does living in
greater harmony with
nature mean?**

**It means living
happier, healthier, and longer.**

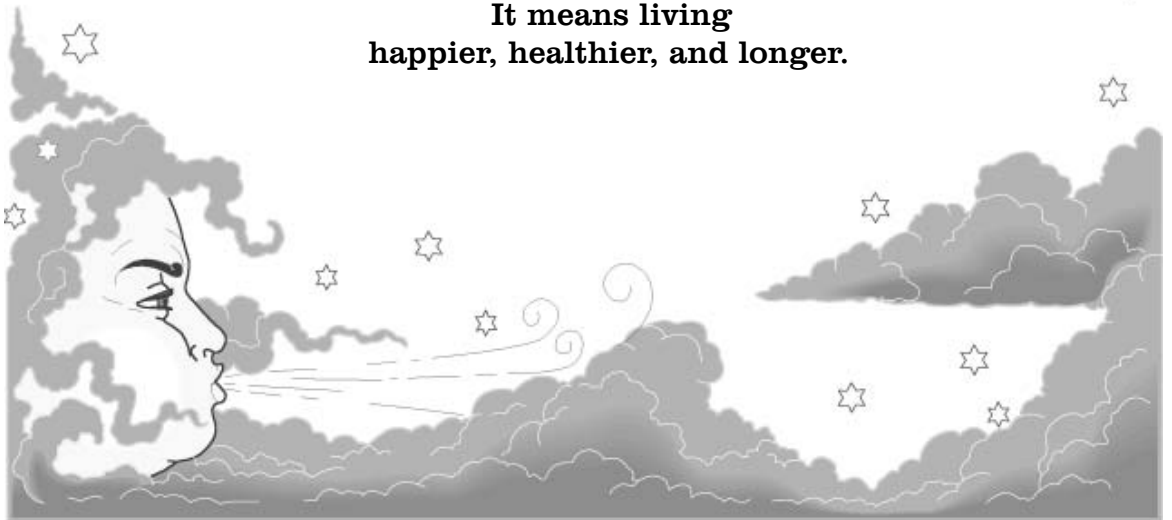

Some of Mother Nature's Eco-Principles

Here they are... Read 'em, learn 'em, teach 'em to your dog (Never mind, he already knows them). Teach them to your friends instead.

* Everyone is downstream or downwind from someone else.
In nature there is no "away."

★ People are a part of the Web of Life
whether or not they realize it.

✈ Every species has a right to be here.

* The earth's resources are here to be used, but
must be used wisely.

☛ Renewable resources must be used no faster
than they can be replaced.

☛ Nonrenewable resources must be reused or recycled, or
they are being wasted.

☛ Mother Nature provides the principles to live by.
If we live by them, we live happy, healthy, and long lives.
If we don't, we get bodyslammed.

* Mother nature recycles everything: the air, the land, the
water. Nothing in nature is ever wasted.

★ People have a unique power to change the world.

⌚ We cannot have a healthy economy in a sick environment.
They're both important.

The Web Spin

People and nature are connected. We affect nature. Nature affects us. We are all connected to each other through the Web of Life. Many people don't SEE their connection to nature, but it's real.



The Effect

A drawing of a person and a drawing of the web of life magically melt together illustrating the connection that exists between people and nature.

What You Need

- drawing of a person & the web of life (you can trace or copy the one we've provided)
- drawing of the web of life
- tape
- pencil

What You Need To Make

1. Make a copy of illustration 1.
2. Cut out along the thick black line. (See illustration 1)
3. Fold illustration 1 in half along the dotted line. (See illustration 1)
4. Tape the pencil in the middle. (See illustration 2)
5. Fold the card down and tape it shut. (See illustration 3)
6. Now you're ready to go.

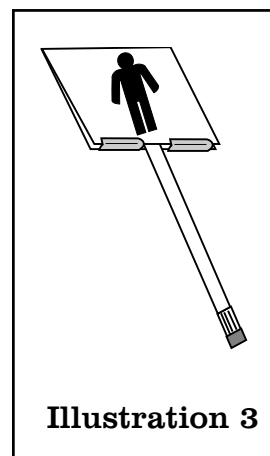
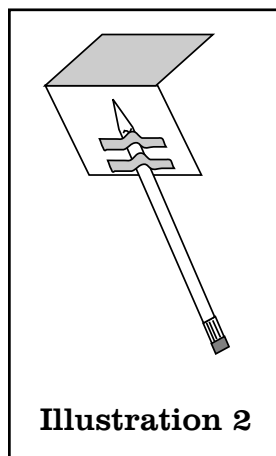
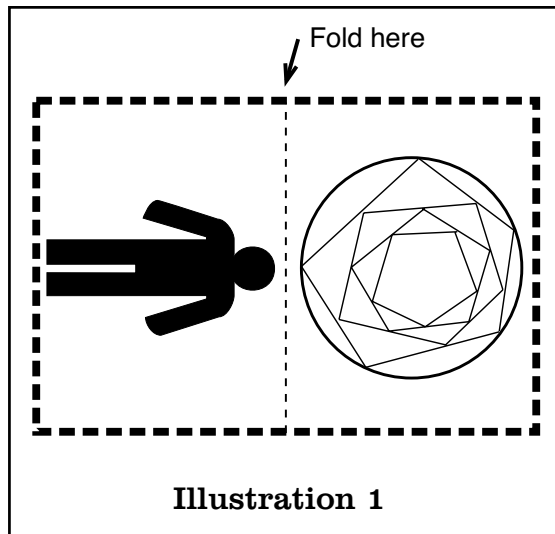

Showtime

1. Show the “person” on side one. Say “People and nature are connected.”
2. Show the “web of life” on side two. Say, “Nature and people are connected.”
3. Say, “They appear to be separate, but they are not. Watch.”
4. Spin the pencil between your hands (as if you are rubbing them together to stay warm). (See illustration 4) This will spin the pencil and drawings together. It will create the **OPTICAL ILLUSION** that the two images are blended together. This is a cool science principle that appears to be a magic trick that illustrates a different science principle. Whew that's tricky!

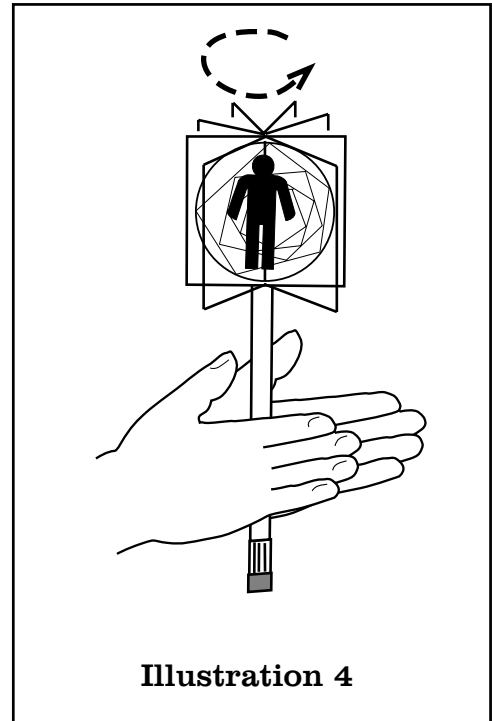

Illustration 4

Vanishing Garbage

When we throw garbage away, it doesn't disappear.
It just goes somewhere else.

Remember, in nature there is **NO AWAY**.

Your **AWAY** is always going to be someone else's **RIGHT HERE**.



The Effect

A small garbage can is shown to the audience. It is thrown into the air and vanishes. You reach into your pocket, and there it is. Your away is someone else's right here!

What You Need

- two small garbage cans (they must be the same size and color.)
- piece of black elastic (at least two feet long)
- small match stick (broken in half)
- safety pin
- jacket or coat

Secret Set-Up

1. Make a small hole in the bottom of one of the small garbage cans. Make it just large enough to push the elastic through.
2. Push the elastic through this hole.
3. Tie this end of the elastic to

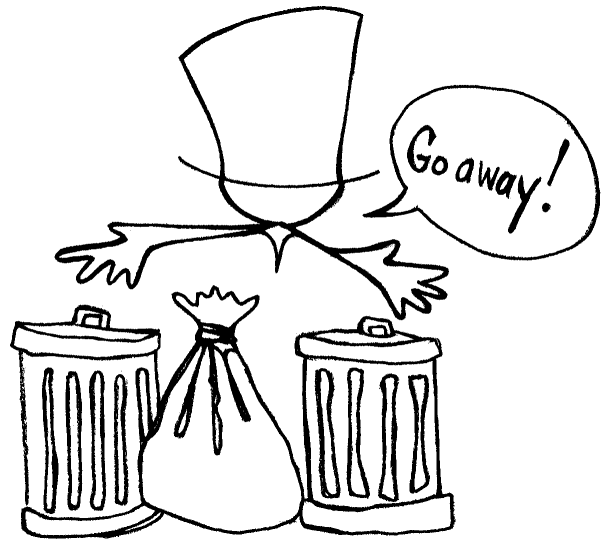

the match stick. (See illustration 1)

4. Tie the safety pin to the other end of the black elastic (not too tight... you will need to adjust it).
5. Hook the safety pin to the inside middle of your jacket. (See illustration 2)
6. Pull the garbage can around the left side of your body with your right hand and put it in your left hand. Put on the coat. It should easily stretch to this position. If it doesn't, then

lengthen the amount of elastic you are using. Your coat and left arm should hide the elastic. (See illustration #3) As you move your hand up and away from your body, the tension will increase on the elastic. Let go and the garbage can will fly back under your coat. Practice this secret move because it is the essence of this trick.

7. Before the show starts, put the ungimmicked garbage can (the one with NO elastic attached to it) in your right coat pocket.
8. Take the gimmicked garbage can and put it in your left hand. The elastic should be hidden by the arm and your coat. Now you're ready to go.

Showtime

1. Show the garbage can in your cupped left and right hands. (See illustration 4)
2. Tell your audience, "When you throw away your garbage, it doesn't disappear..."
3. While you're saying this, cup your right hand over the top, hiding the garbage can. (See illustration 5)
4. Simultaneously turn your body to the right and lift both hands up, forward, and to the

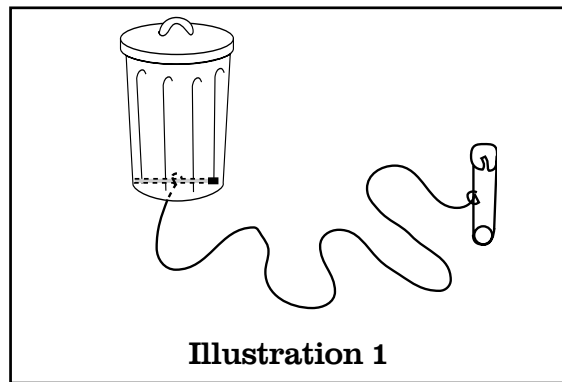

Illustration 1

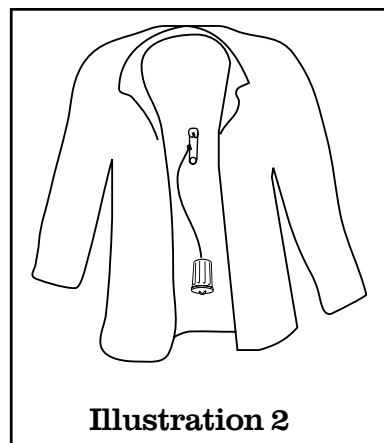

Illustration 2

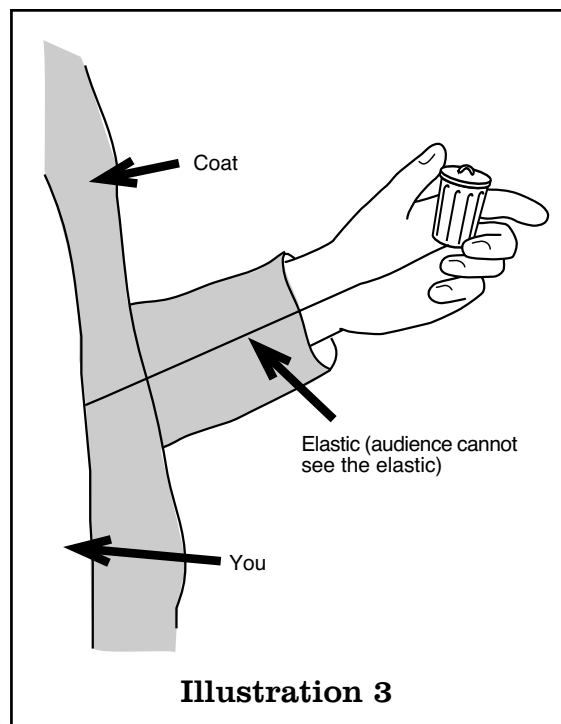

Illustration 3

right. As you do this, let the garbage can secretly shoot back under your coat. The elastic pulls it into the coat.

5. Rub your hands together as if you're making the garbage smaller and smaller and smaller. Blow on your hands.

6. Then open your hands to show that the garbage can has disappeared. And say, "Your garbage doesn't disappear it just goes somewhere else."

7. Reach into your jacket pocket and pull out the second garbage can. The audience will believe it's the one you just made disappear!

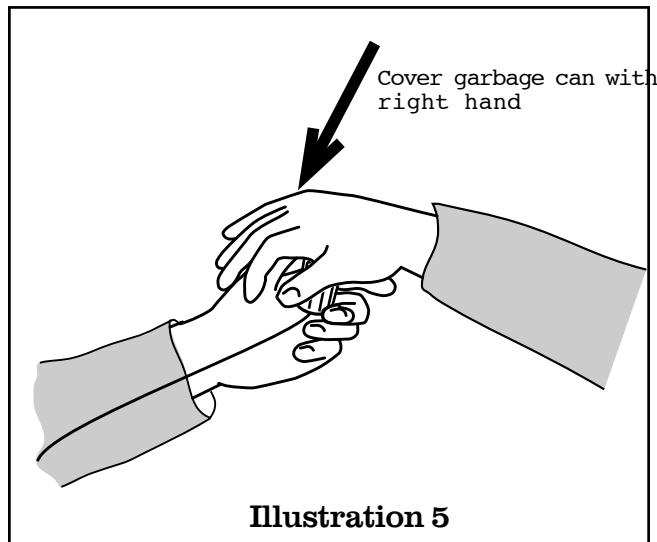
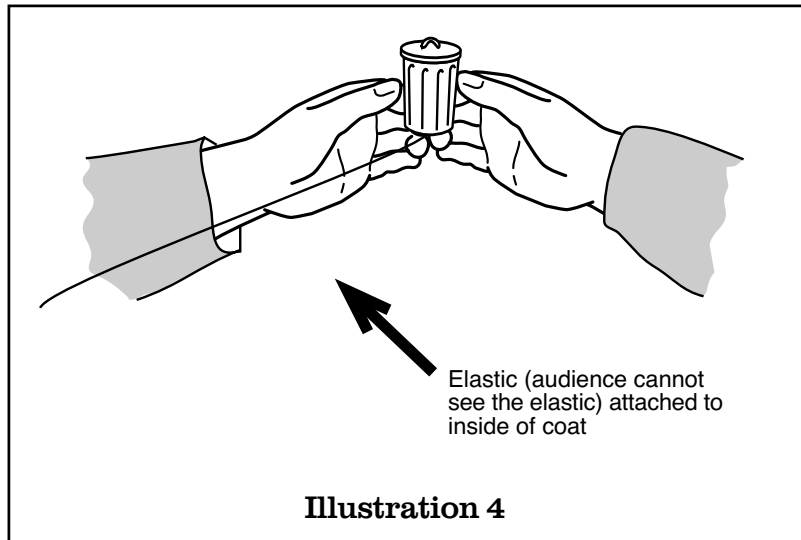

Recycled Pencil Transformation

Buying recycled stuff is one of the best ways to make recycling even more successful. There are many things that you can buy that are made of recycled materials including pencils. The recycled pencil is usually made of recycled paper and cardboard. Here's a trick you can do with a recycled pencil.



The Effect

Some wooden pencils are shown in a steel can (like soup comes in). One pencil is pulled out and shown (It's red). It is rolled up in a piece of paper. The magician says, "Buy recycled stuff." The pencil is poured out of the piece of paper onto the table. It has magically changed from red to yellow. It's also now a recycled pencil made of recycled newspapers and cardboard.

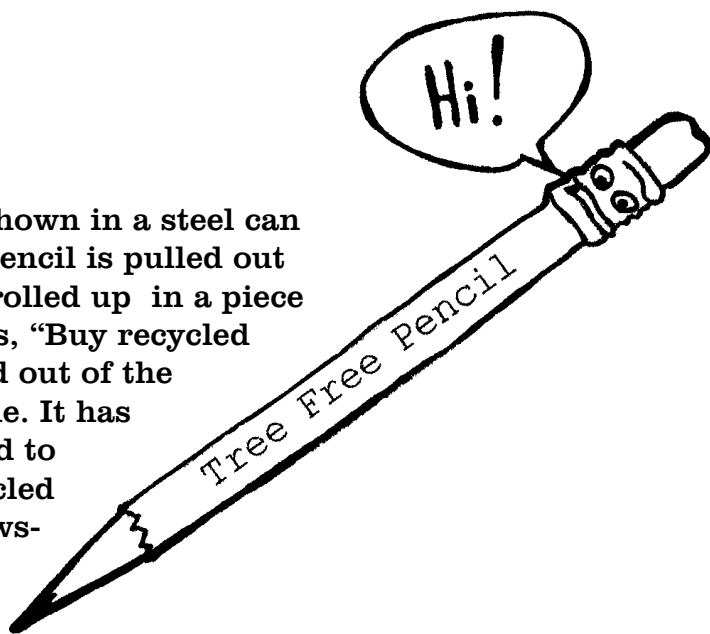

What You Need

- unsharpened recycled pencil (yellow)
- tin or steel can (just like soup comes in)
- five or six pencils of various colored handles (unsharpened)
- writing paper (approximately 10 inches by 10 inches)
- shiny red gift wrapping paper
- scissors
- yellow crayon

Secret Set-Up

1. Make a red paper shell gimmick. Cut the shiny red paper to fit around the pencil. (See illustration 1) Wrap it around the recycled pencil.
2. Glue or tape the red paper along its seam. It now makes a shell that can slide easily on and off the recycled pencil. Try it a few times. (See illustration 2)
3. Put the gimmicked pencil (with the red shell on it) in the can with the other pencils.

4. Write the letters W-O-O-D on a piece of writing paper with a yellow crayon. (See illustration 2)

Showtime

1. Bring out the can of pencils. The gimmicked pencil is mixed in with them. Shake the pencils.
2. Pull out the gimmicked red pencil. Say, "This pencil is made of wood." Point to the piece of paper that says W-O-O-D with the gimmicked pencil.
3. Now roll the gimmicked pencil up in the piece of paper that says W-O-O-D. Roll it pretty tight. Say, "Watch this...this pencil is now a recycled pencil made of recycled paper and cardboard."
4. Hold the pencil upright and let it slide out of the rolled paper. The red shell should not slide out with the pencil. (See illustration 3)
5. Crumple the piece of writing paper into a ball and put it into your pocket. This destroys the evidence of your secret red paper gimmick.
6. Hand the pencil out to your audience for examination.

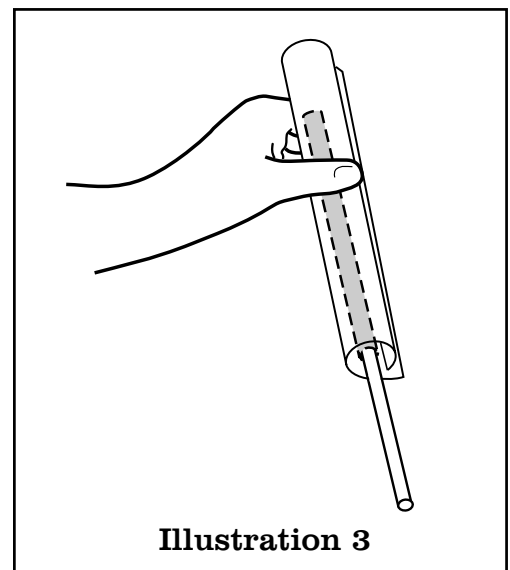
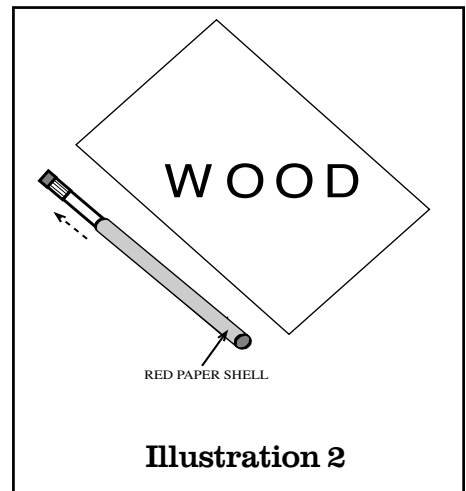
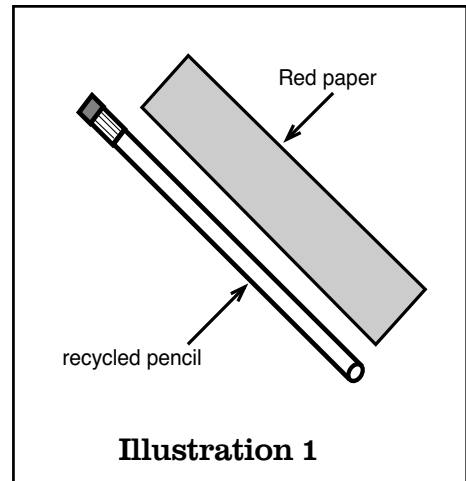

Vanishing Silver Pebble

The earth's resources should be used, but they should be used wisely. Remember these two principles whenever you want to use a resource:

- (1) Renewable resources must be used **NO FASTER** than they can be replaced.
- (2) Nonrenewable resources must be recycled and reused again, or they are being wasted.



The Effect

A small pebble painted silver (representing the nonrenewable mineral silver) is dropped into a glass of water. It's covered with a bandanna. You say, "Nonrenewable resources that aren't recycled... are being wasted." The bandanna is taken away from the glass, and the silver pebble is gone.

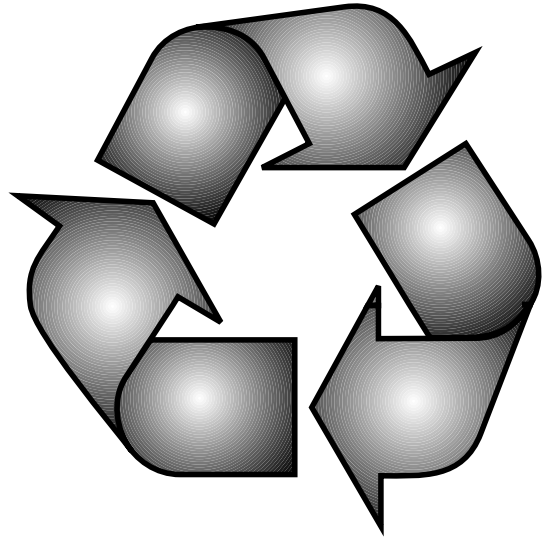

What You Need

- two small flat pebbles
- silver paint
- clear tape
- dark colored bandanna or scarf. (black, blue, red, purple, etc.)
- piece of thread (the same color as the bandanna)
- glass of water
- empty glass
- scissors
- box (a shoe box will do nicely)
- sewing needle
- table
- glue

What You Need To Make

1. You need to make a special gimmicked bandanna. Lay the bandanna out flat on a table.
2. Sew a piece of thread to the center of this bandanna.
3. Tape the first silver pebble to the thread about 7 inches from the bandanna.
4. Trim off the extra thread below the taped pebble.
5. Turn your bandanna completely over.

6. Now pick up the bandanna by the middle with your left hand. The pebble will hang down, but you should not be able to see it. (If you can see the pebble, shorten the thread, and tape the pebble back on again.) (See illustration 1)

Secret Set-Up

1. Now, with your right hand reach under the folds of the bandanna and grab the attached pebble A.
2. Put pebble A (under the bandanna) into your left fingers. You are now holding the pebble through the bandanna. (See illustration 2)
3. Lay this down so you can easily grab the pebble and bandanna together. Lay it in the box.
4. Set the glass of water into the shoe box.
5. Set the second pebble into the shoe box.
6. Set the empty glass into the shoe box.
7. Carefully set the shoe box in the center of your table. (See illustration 3)

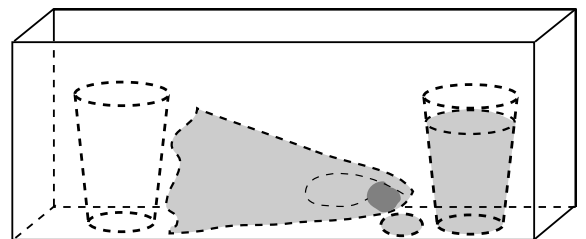
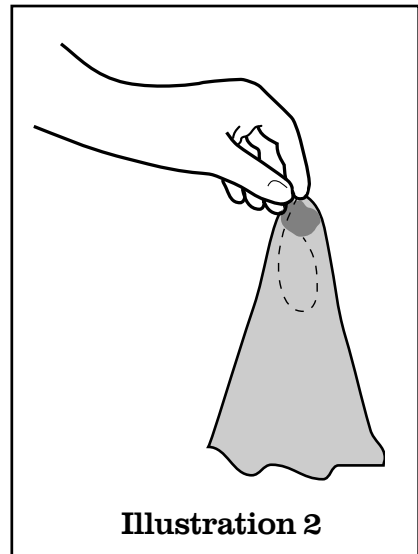
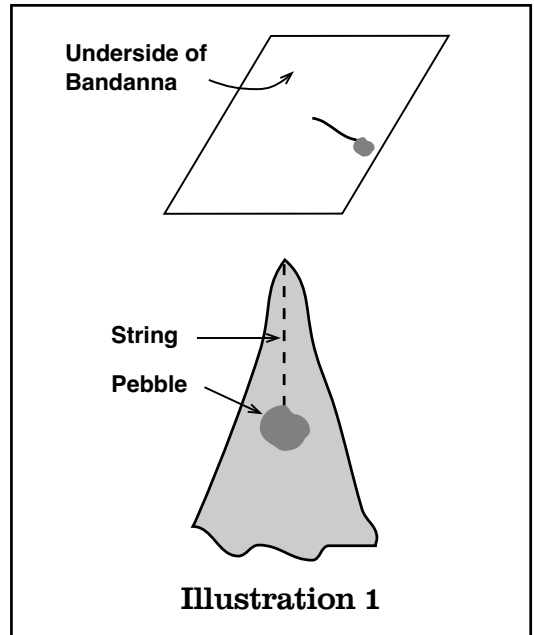
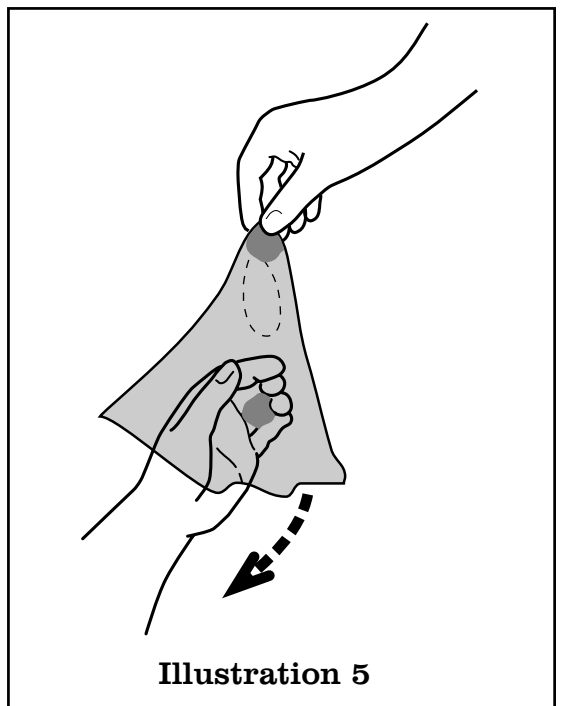
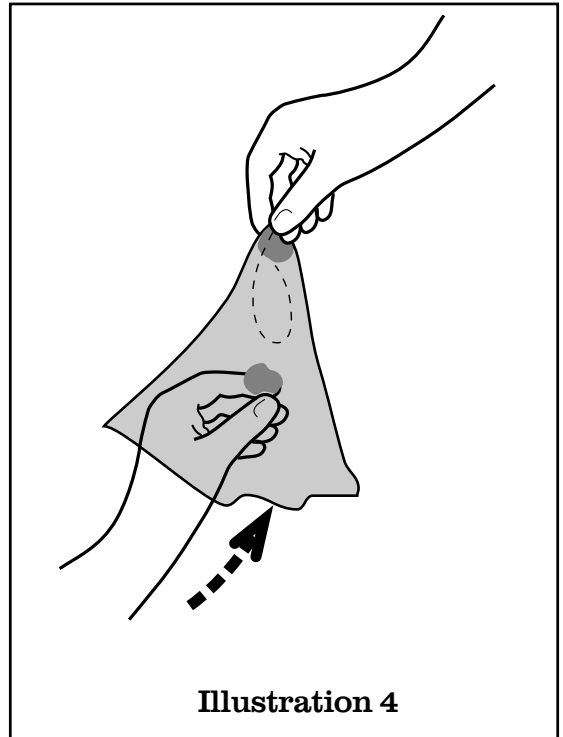

Illustration 3

Showtime

1. Take the glass of water out of the shoe box and show it to everyone. Set it back into the box.
2. Pick-up the gimmicked bandanna with your right fingers.
3. At the same time, pick up the second pebble with your left fingers.
4. Show the pebble with your left hand to the audience.
5. Put this pebble under the bandanna. It should look like you're putting it into your right hand through the bandanna. (You're not really doing this.) (See illustration #4)
6. Your left hand secretly keeps it's pebble as the bandanna is pulled away to the right. (See illustration #5)
7. The shape of the attached pebble is seen through the fabric of the bandanna in the right hand, as if it were the other pebble.
8. Casually drop the pebble (held in your left hand) into the shoe box as you pick up the glass of water. (Don't be nervous about this; no one will suspect.)
9. With your left hand, hold the glass up for everyone to see.



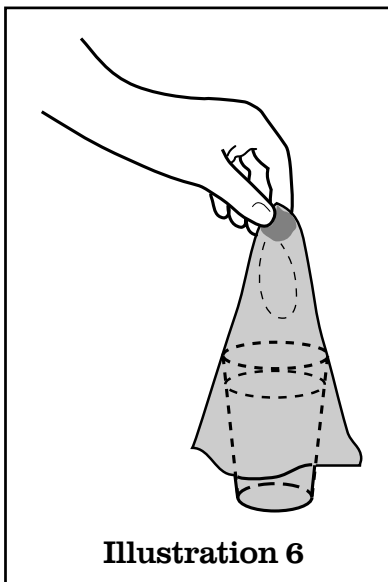

Illustration 6

- Your fingers should be at the bottom of the glass.
10. Drape the bandanna over the glass with your right hand. (See illustration 6)
 11. Carefully drop the attached pebble into the glass of water. Let everyone hear it drop. (See illustration 7)
 12. Now you say, “Resources that aren’t used wisely... disappear.”
 13. As you say the word, “disappear,” pull the bandanna up and away from the glass. Show everyone that the pebble has vanished. Then, lay the bandanna back into the box.
 14. Grab the empty glass from the shoe box with your right hand.

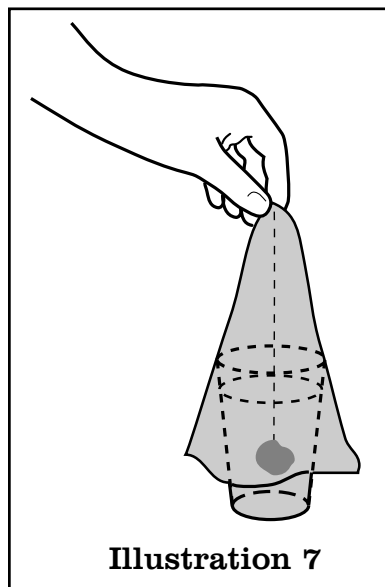

Illustration 7

15. Pour the water from the full glass into the empty one. The pebble has vanished completely.

NOTE: If you want to hand out all of the items for inspection after the trick, you’ll need to do a little more work. Here’s what you need to do. Wad up an extra bandanna, just like the special one, in your right rear pocket. As you lift the bandanna with the attached pebble off the glass of water, put it into your back pocket. Pour the water into the empty glass. Set the full glass down. With your right hand, reach into your back pocket and pull the extra bandanna out (not the special bandanna) and dry off the wet glass. The audience will believe it’s the same bandanna. Then you can hand everything out. **Wow! What a great trick...**

Linking Paper Clips

We cannot have a healthy economy in a sick environment. Our economy and our environment are so tied together, that to survive, **BOTH** must be cared for.

Economy = how people make and spend wealth.
Environment = the natural world around us.

People who aren't able to meet their own survival needs (food, clothing, shelter) will do **whatever** it takes to meet them. This includes destroying their own environment or someone else's. So, it's essential to have an economy that gives access to all biological (stuff we gotta have to live) needs without destroying the environment. People who don't have a healthy environment to live in won't be well enough to support a healthy economy. People who don't have a healthy economy won't be well-off enough to support a healthy environment. They both must work together cooperatively.



The Effect

Two paper clips (one represents the economy and the other represents our environment) are magically linked together.

What You Need

- two paper clips
- one dollar bill
- cardboard
- scissors
- green marker

Secret Set-Up

Cut the cardboard into two small rectangles (two inches by three inches). Write the word "Economy" on the first card with the green marker. Write the word

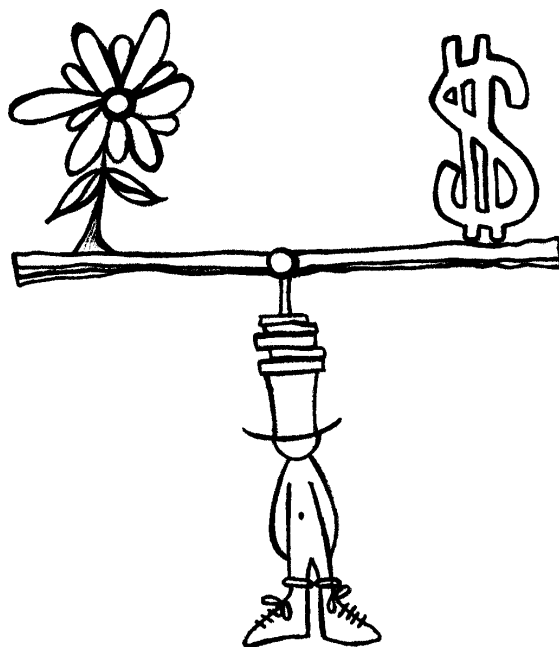

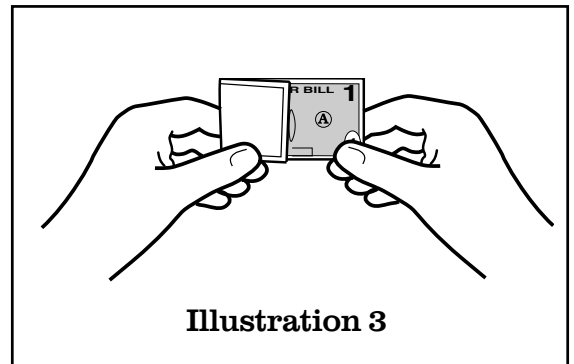
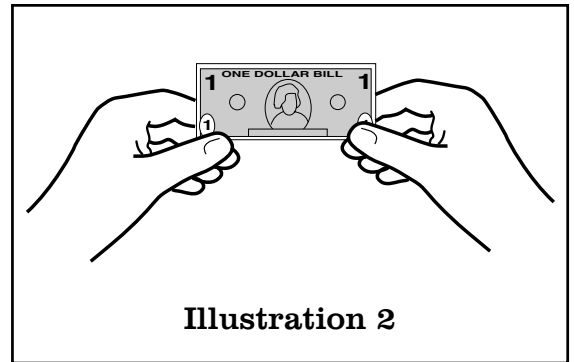
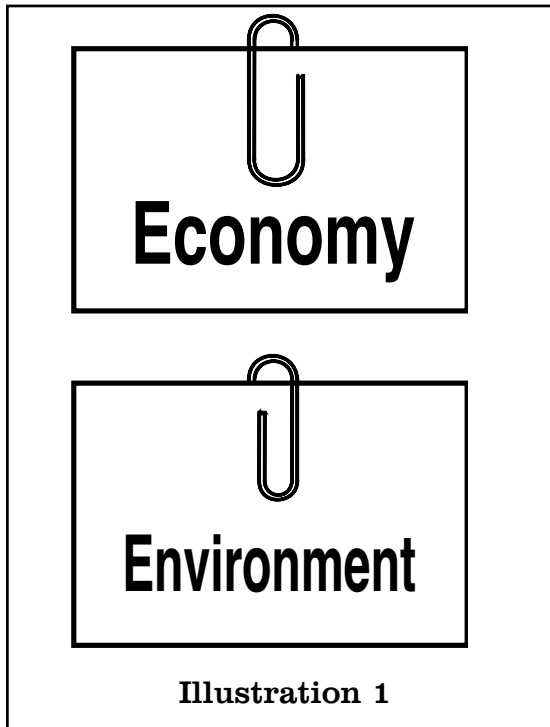

“Environment” on the second card with the green marker. Attach one paper clip to the top of each card. (See illustration 1)

Showtime

1. Take the first paper clip off the “environment” card. Say, "This paper clip represents our environment." Set the card to the left on the table.
2. Take the second paper clip off the “economy” card. Say, "This paper clip represents our economy." Set the card to the right on the table.

2. Hold the bill open between both hands. Say, “This dollar bill represents the invisible link between both of them.” (See illustration 2)
3. Fold one third of the bill over to the right. (See illustration 3)
4. Push the “environment” paper clip over this fold. (see illustration 4)
5. Turn the bill around (not over) so you can see the other side.

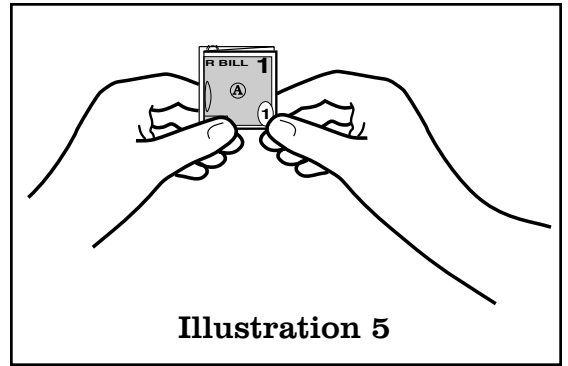
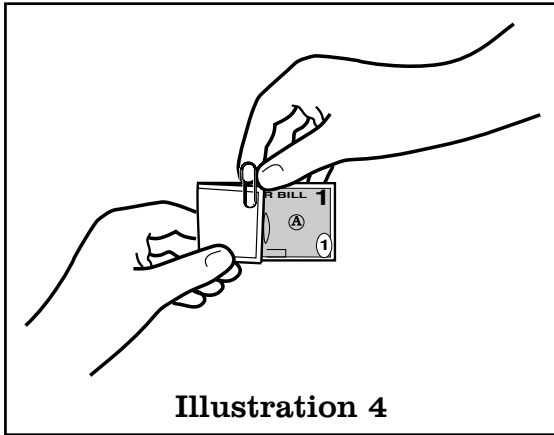

6. Fold the left end back over to the right side. (See illustration 5)

7. Put the “economy” paper clip on the bill from the top. (Clip only the front two folds.) (See illustration 6)

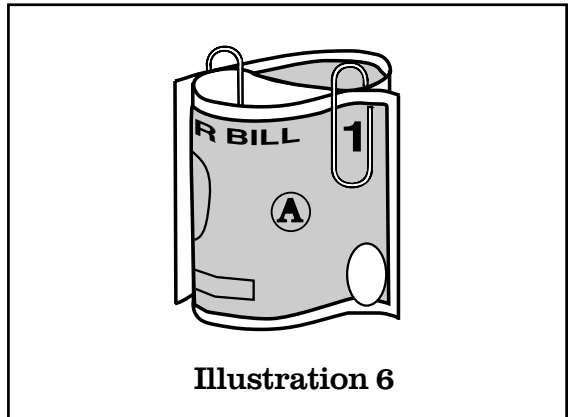

8. Pull the ends of the bill.

9. The paper clips will attach to each other like magic and fly off the bill. (See illustration 7)

10. Pick them up and show they're linked. Say, “It is an illusion to believe that the environment and the economy are not connected.” Excellent!

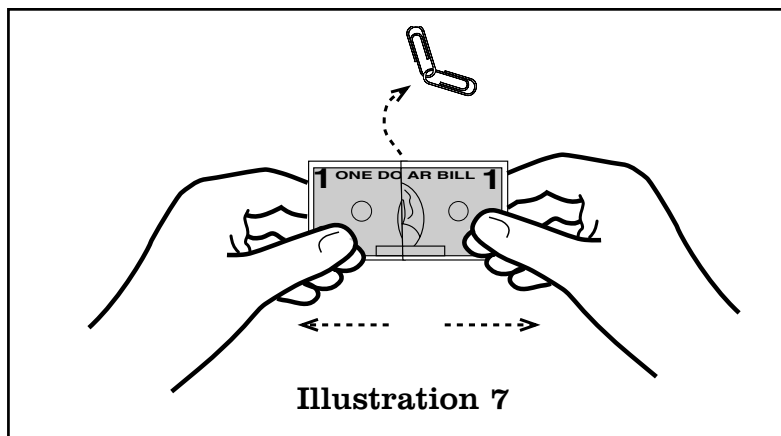

Water in the Boot

Mother nature recycles everything: the air, the land, the water. Nothing in nature is ever wasted!

Mother Nature is the ultimate recycler! Take water for example. The water that you drink from your faucet is the same water that fell as rain last month and the same water you took a bath in last year. Yucky but true. That same water has been recycled over and over for millions and millions of years. The same water is continually being cleaned up, recycled, and reused by mother nature.

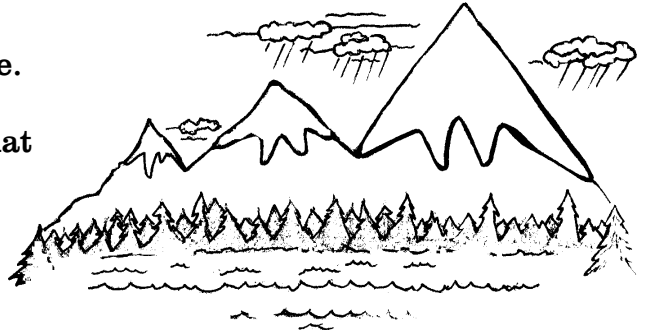

The Effect

A cup of water is dumped into a stinky work boot. The magician places a cup into the boot and orders the water to recycle itself back into the cup. Reaching into the boot, he removes the cup. The water has jumped back into the cup. Magically, the boot is dry and the cup is full of water.

What You Need

- one old, ratty, ugly, work boot (try to find one at a local thrift store... the bigger the better)
- two small paper cups with a rim at the top
- scissors
- a large glass of water
- your own personal magic wand

What You Need To Make

1. Cut out the bottom of cup #1.
2. Cut off the top rim of the cup #2. (See illustration 1)

Secret Set-Up

1. Place cup (#1) with the rim into the cup with no rim (#2). These will nest together and look like one cup. Everyone should think that it is only one cup. (See illustration 1)

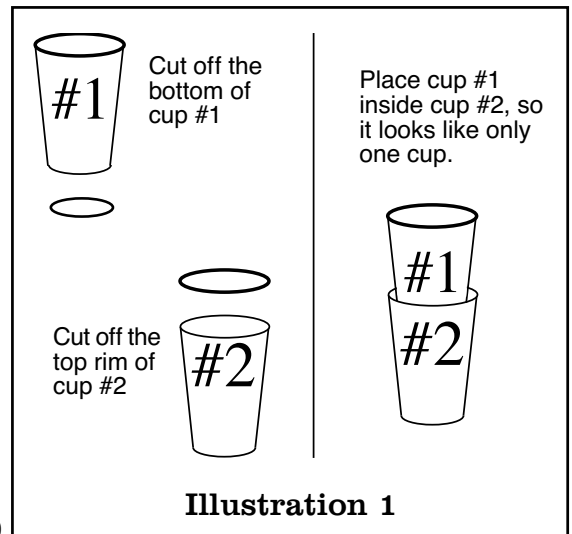

2. Put the glass of water and nested cups on the table.

Showtime

1. Show the nasty, beat-up, work boot. Pretend that it smells bad. (Everyone will laugh at this.)
2. Lift the nested cups show and put them into the boot. Say, "a cup".
3. Tell the audience that mother nature recycles water so we can use it again. Even dirty, stinky water is recycled.
4. With your right hand, take the bottomless cup out of the boot leaving the cup with no rim. (Separate the cups using your thumb and first finger.) The cup left in the boot is hidden from the audience. (See illustration 2)
5. Set the bottomless cup on the table. Don't let people see that there is no bottom to this cup.
6. Pour water into the cup with no rim. It will look like you are pouring water right into the tennis boot.
7. Say "This dirty, stinky, water is now being recycled into clean water by mother nature." Pick up the bottomless cup and slide it back into the cup that has water in it. (See illustration 4)

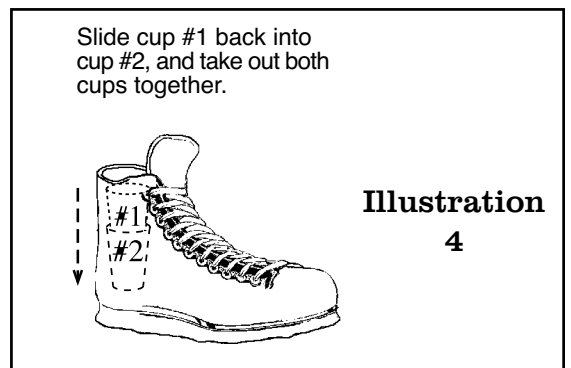
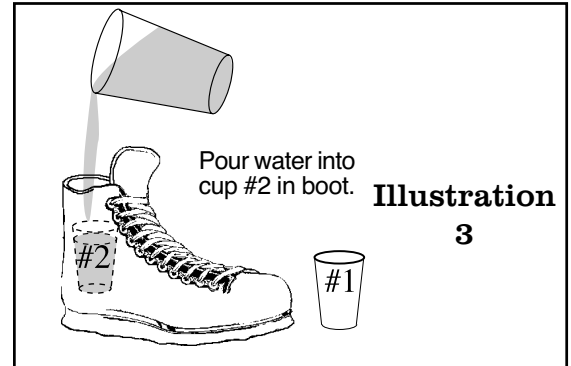
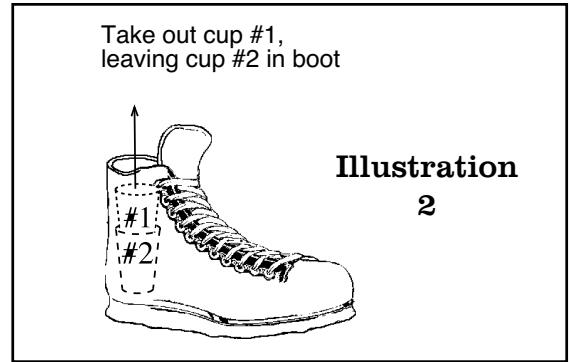

8. Order the water to get back into the cup. Say, "get back in the cup dirty stinky water".
9. Wave your magic wand over the cup and boot.
10. Take the nested cups out together. Dramatically pour the water in the cups back into the big glass of water.

Magic Wand from Coin Purse

People have an impact on the world around them.

Young Eco-Heroes are people that have chosen to have a positive impact on the world. Their goal is to “heal” the planet peacefully. The power to “heal” the planet is available to anyone who chooses to use it.

- ☆ Respect yourself.
- ☆ Respect others.
- ☆ Respect the environment.

When you start doing these things, it’s as if you have created your own personal magic wand. You can have a very positive impact on the world. We need your help. So get out there and do something to make the world a better place to live!

The Effect



A small coin purse is shown to the audience. Three pennies are taken out of the purse. The magician then looks inside the purse and can’t believe what she sees. There is a large magic wand inside. The magic wand is pulled out of the purse for the audience to see. It is almost four times larger than the purse!

What You Need

- small coin purse
- scissors
- three pennies
- magic wand (approximately ten to twelve inches long)

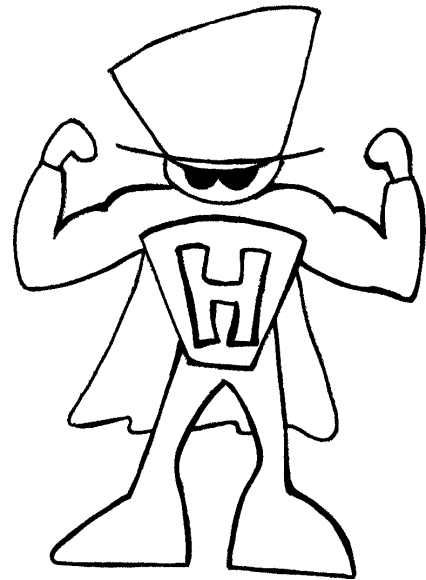

- two rubber bands
- a long sleeve shirt or jacket
- bright colored water based paint (red, yellow, blue)
- paint brush
- water for clean-up

What You Need To Make

1. Cut a hole in the bottom left corner of the coin purse. Make the hole just large enough for your magic wand to slide into. (See illustration 1)
2. Paint your magic wand a bright color.

Secret Set-Up

1. Roll up your left sleeve.
2. Put one rubber band on your left arm near your wrist.
3. Put another rubber band on your left arm near your elbow.
4. Now, slide the wand under the rubber bands. (See illustration 2)
5. Roll your sleeve down.
6. Put the four coins in your purse.
7. Set the purse on your table. (Don't let the coins fall out of the secret hole.)

Showtime

1. Pick up the change purse with your right hand.
2. Put the purse into your left hand and secretly slide the wand into the hole in the purse. (See illustration 3)
3. With your right hand, open the top of the purse and take the four pennies out. Set them on the table.
4. Look into the purse. Look surprised and then look again.
5. Pull the giant magic wand out of the purse. Tap it on your table. This shows that the wand is solid. (See illustration 4)

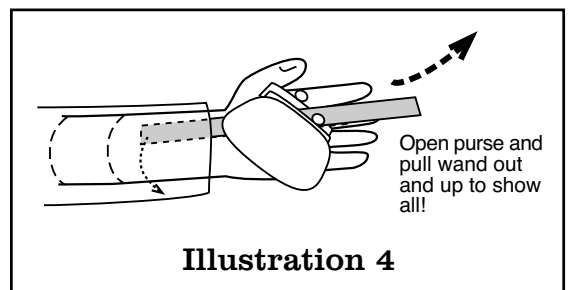
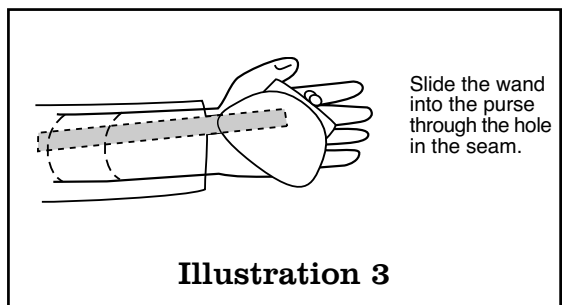
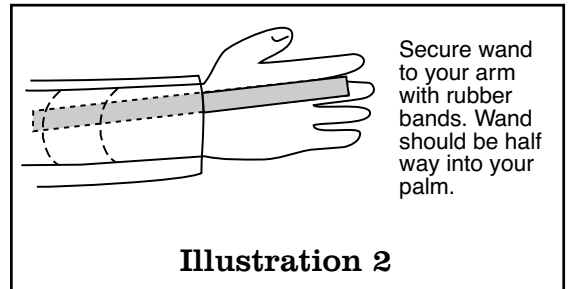
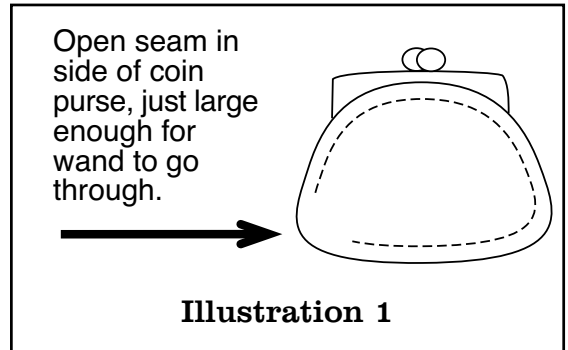

6. Smile graciously and do a little dance because you're so cool!

Greenhouse Penetration

Gases in our atmosphere trap reflected heat at the earth's surface. It's called the "greenhouse effect." This is not only a good thing. It is absolutely necessary. If these gases didn't trap heat, we would all freeze to death.



The Effect

A borrowed coin representing energy from the sun penetrates a solid paper bag that is tied shut.

What You Need

- table
- paper bag or sack (lunch bag size)
- borrowed coin
- cardboard toilet paper roll tube
- rubber bands
- large cardboard prop box
- yellow or orange crayon
- string (about eight inches long)
- table
- small cloth bag (approximately three inches by four inches)

Secret Set-Up

1. Punch a small hole into the toilet paper tube at the top.(See illustration 1)
2. Thread your string through this hole. (See illustration 1)
3. Punch two holes in the large cardboard prop box near the top. (See illustration 2)
4. Slide the cardboard tube into

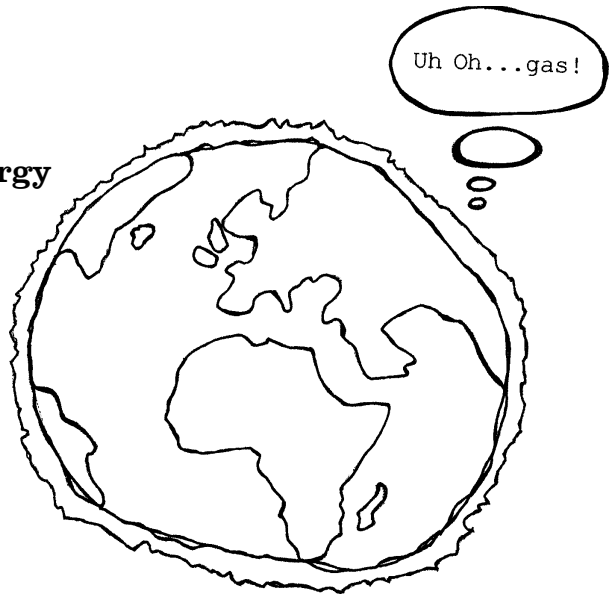

the neck of the small bag.
(See illustration 3)

5. Wrap two rubber bands around it.

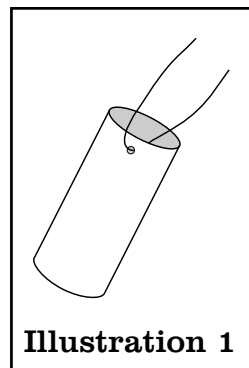

Illustration 1

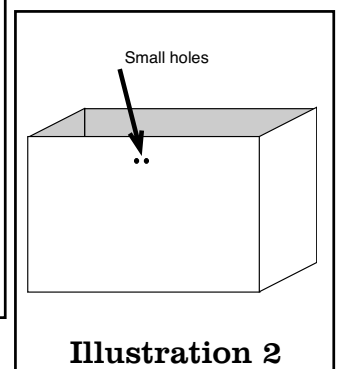

Illustration 2

6. Now put the tube and small bag into the paper bag and wrap two rubber bands around it. (See illustration 4)

7. Tie the loop of string through the holes of your large cardboard prop box. The bag should hang freely. (See illustration 4)

7. Leave this in your large cardboard prop box.

8. Put the cardboard box to your left on the table.

Showtime

1. Borrow a coin from someone in your audience.

2. Have them draw a small sun on both sides of the coin with the crayon. (This will represent the sun's energy.)

3. Hold the coin in your right hand. (See illustration 5) Put it in your left hand and say, "This coin represents the sun's energy."

3. Put the coin back in your right hand. Say, "The sun's energy is trapped by the greenhouse effect. Watch."

4. While you're saying this, pretend to put the coin into your left hand. Secretly keep it in your right. (See illustration 5 and 6)

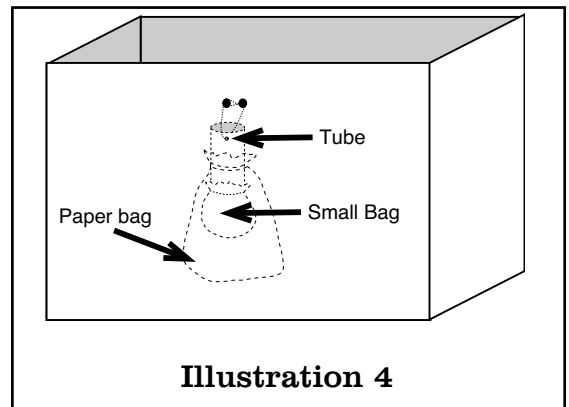
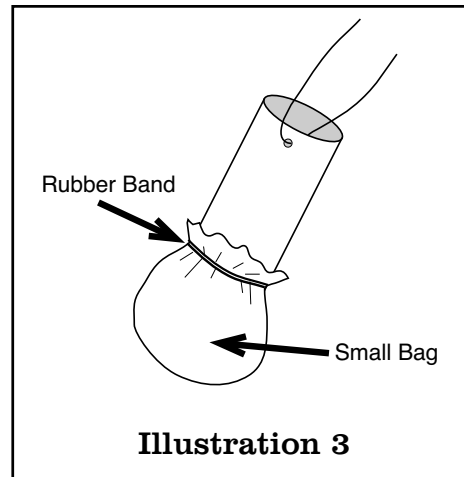

5. Hold your left hand up high in the air.

4. Reach into the box with your right hand.

5. Secretly drop the coin into the tube.

6. Quickly, pull the bag down and free from the tube. The rubber bands will tighten around the neck of the bags with the coin inside.

(See illustration 7)

7. Bring the bag into view with

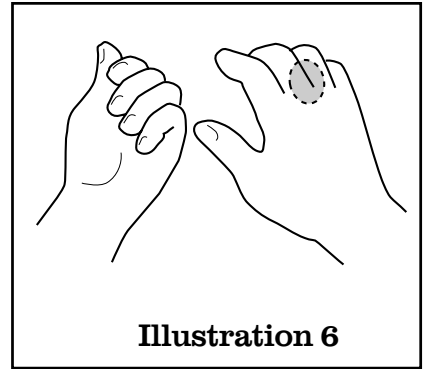
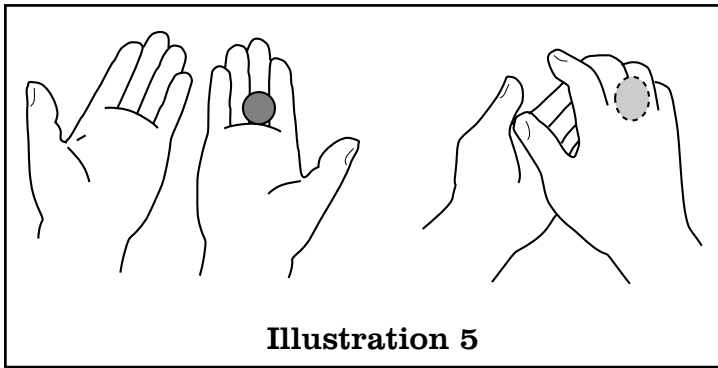

your right hand. Hold it up high. Say, “The sun’s rays are trapped by the earth’s atmosphere. The atmosphere is like this bag. The marked coin is like the energy from the sun. Watch.”

8. Take your left hand (which supposedly has the coin in it) and hit the side of the bag gently. (See illustration 8)
9. Show your empty left hand.
10. Shake the bag. Everyone will hear the coin rattling inside.
11. Have someone in your audience open the bag to see that the coin is now trapped inside.

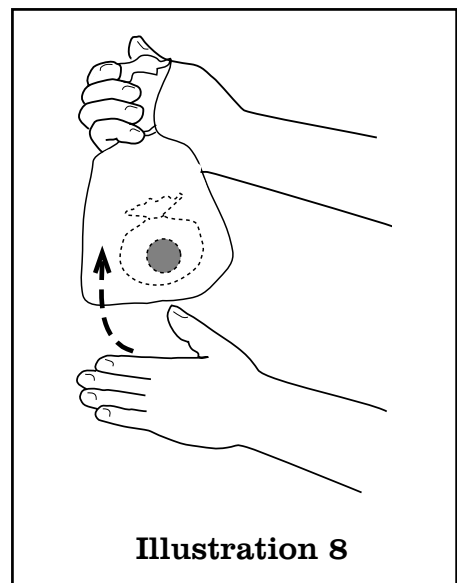
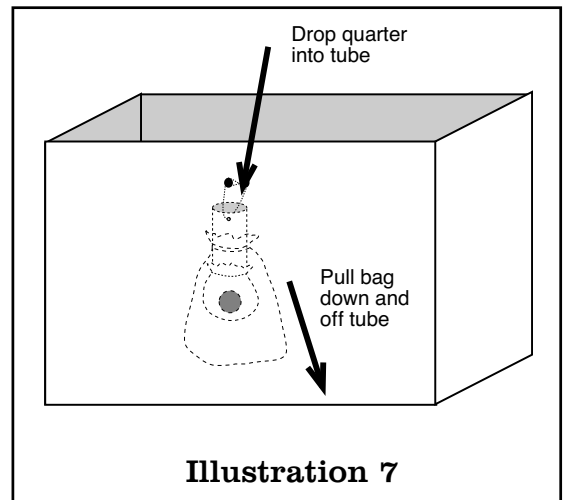

Green Milk

Everyone is downstream or downwind from someone else. In nature there is no such thing as “away.”

People all over the world share the same land, the same oceans, and the same air. You may not know it, but someone that lives clear across town can pollute your drinking water. Say what? Yeah, they can. Let’s say you’ve got a boneheaded person who decides to dump his used motor oil onto the ground. What happens to that oil? First, it will to soak into the ground. Eventually it will seep through the ground all the way down to **YOUR** ground water. (Millions of people get their drinking water from wells drilled into underground rocks that are fed by the water table.) If your personal drinking water comes from a well or an aquifer, guess what? You could have this problem, too.

Pollution is the right resource in the wrong place at the wrong time in the wrong amount.



The Effect

Toxic green dots vanish from a handkerchief and change a glass of milk to an ugly toxic green color.

What You Need

- green food coloring (Be careful. This stuff will stain your clothes and you’ll need “real” magic to get it out.)
- two clear drinking glasses
- carton or jug of milk
- large sheet of newspaper
- two white cloth handkerchiefs or bandannas
- green magic marker
- spoon

- table
- thin piece of cardboard (one inch taller than the glass you’re using)
- tape
- glue (rubber cement is actually better)
- towel in case you spill anything
- cardboard prop box

What You Need To Make

1. Glue a special **Vanishing Newspaper** together just like the illustration. Use a thin layer of glue, so it won’t wrinkle the paper. (See illustration 1).

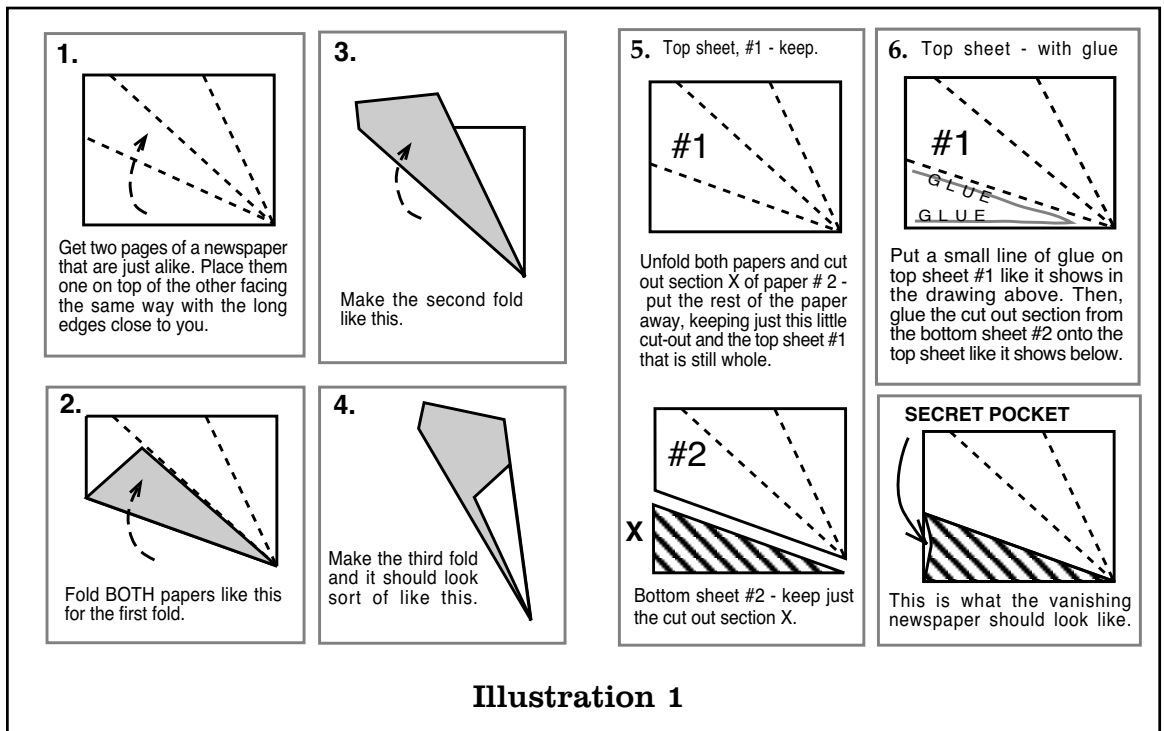

Illustration 1

2. **Make the green toxic dot handkerchief. Draw lots of different sized circles and weird shapes on the handkerchief and fill them in with the green marker. Make it look real scummy. Draw on both sides.**

3. **Roll the thin cardboard to make a tube and tape it. It should fit easily over the clear glass of milk. (See illustration 2)**

Secret Set-Up

1. **Put three drops of green food coloring into the bottom of the clear glass. Don't get any on the sides of the glass. We don't want to tip the audience that we're using food coloring.**

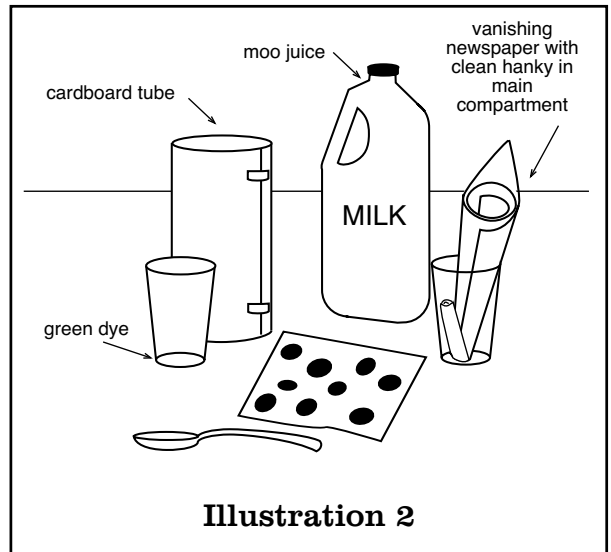

Illustration 2

2. **Roll the special Vanishing Newspaper into a cone.**

3. **Put the handkerchief (with no dots on it) into the main compartment of the special Vanishing Newspaper cone.**

4. Set the glass with the food coloring on the table to your left.
5. Set the secret **Vanishing Newspaper** cone (with the blank handkerchief in it) upright in the glass to your right. (See illustration 3)
6. Set the green toxic dot handkerchief on the table between the glasses.
7. Set the cardboard prop box down below the table.
8. Now you're ready to go.

Showtime

1. Show the green toxic dot handkerchief to the audience. Say, "Toxic stuff."
2. Pick up the **Vanishing Newspaper** cone with your right hand. Put the toxic dot handkerchief into the secret compartment of the **Vanishing Newspaper** cone with your left hand.
3. Place the vanishing newspaper cone into the tall glass on your right.
4. Cover the glass on the left side of the table with the cardboard tube.

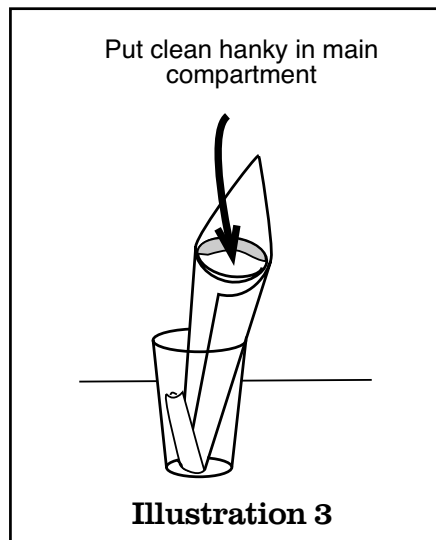

5. Pour the milk from the plastic jug into the glass (with the food color). The audience won't see the food coloring and milk combining because it's covered by the cardboard tube. Don't spill!
6. Put the spoon into the paper cone and pretend to stir the handkerchief up.
7. Now, put the spoon into the cardboard tube and actually stir the milk. The milk will turn green. Say, "When you dump toxic stuff on the ground, it won't just stay there."
8. Now we're ready for the magic! Reach into the main compartment of the cone and pull out the blank handkerchief. The green color is gone.

9. Unroll the cone and show that it's empty. (See illustration 4) The secret compartment won't show. Set the cone into your cardboard prop box below the table.
10. Slowly lift the cardboard tube from the milk and show that the milk is now green.
11. Say, "If we don't watch what we pour onto the ground, we may end up drinking it."
12. Bow to thunderous applause.

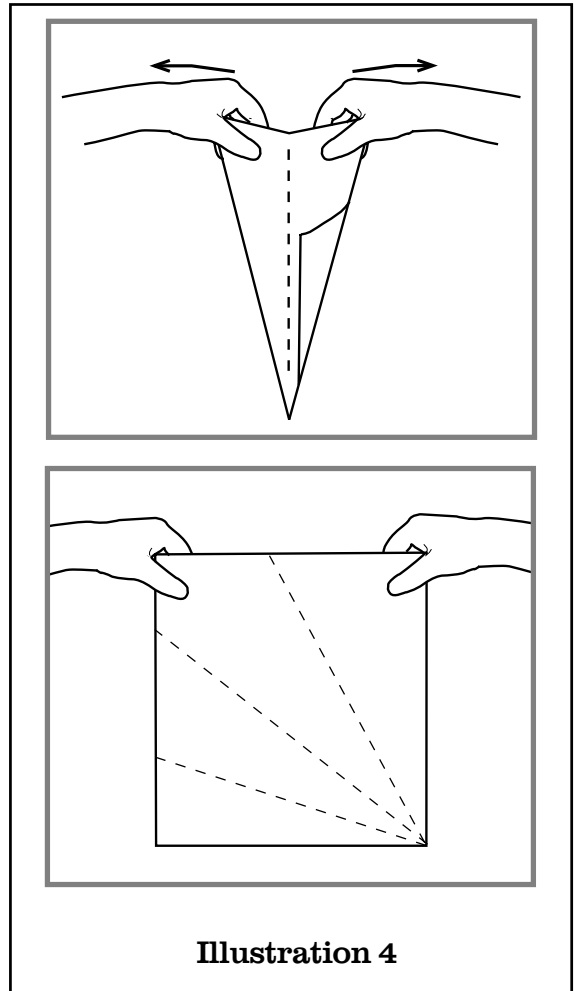

Sun Fun

The sun is a **MASSIVE** supplier of energy. Every single minute it supplies the earth with more energy than humans use (in the form of fossil fuels) in a full year. Imagine that ... a year's worth of energy is supplied to the earth in one minute!

Energy from fossil fuels is limited. Energy from the sun is not!

Solar energy can be collected and used by humans from a variety of sources: photovoltaic cells, hydro-power, wind power, wave power, geothermal, and bio-mass. We are limited only by our imagination.



The Effect

A small rope representing the energy we now harvest directly from the sun (and moon) grows longer as we learn to collect, store, and use the sun's energy more creatively.

What You Need

- jacket
- rope (about 10 feet long)
- a bit of acting

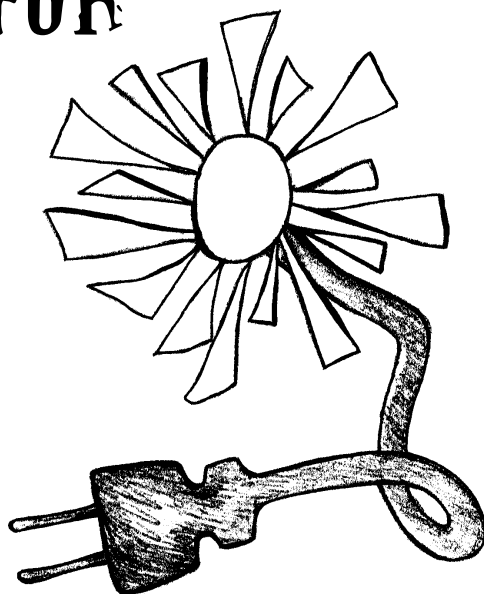

Secret Set-Up

1. Put your jacket on.
2. Grab the rope in the center with your left hand.
3. Stuff the center into your right sleeve. (See illustration 1)
4. Keep stuffing until only a few inches are left poking out.
5. Hold the two ends in your right hand as if they are one short piece of rope. (See illustration 1)

Showtime

1. Show the rope and say, "Sunlight can be converted to electricity by solar power, hydro-power, wind power, and wave power."
2. Grab end A with your left hand.

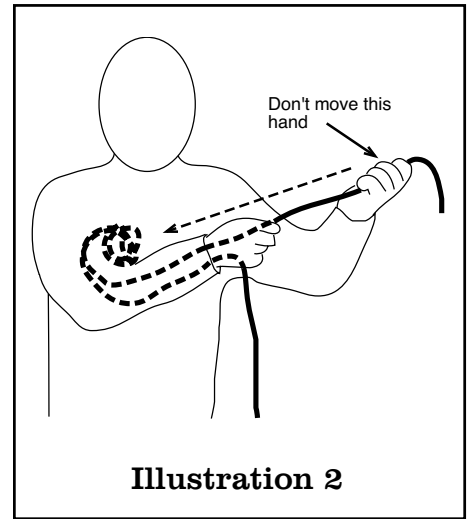
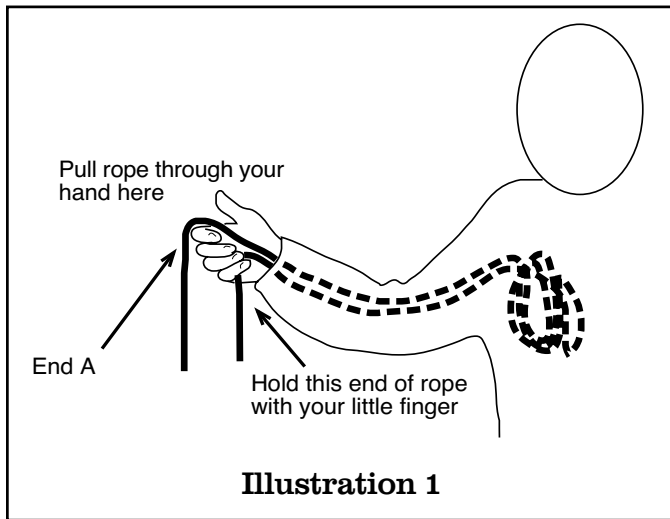

- Turn your whole body to your left.
3. Lift your right and left hands up to shoulder height.
 4. Say, “We can stretch the energy available to us by using current solar income.”
 5. Move your right hand towards your body, letting the rope slide out of your sleeve through your hand. It will look as if the rope is stretching. Do not move your left hand at all! (See illustration 2)
 6. When you have stretched it out about two feet, stop. Let go of the rope with your left hand.
 7. Grab the rope with your left hand near your right hand again.
 8. Lift both hands to shoulder height again.
 9. Repeat step 5.
 10. Continue to repeat the stretching motion until you reach the end of the rope.

Water Planet Cards

We live on a blue planet. It's blue because it's covered with water (water, water, water). Lot's of water! Water or H₂O is an essential ingredient of life. No water, no life. So far, the only planet we've found that has liquid water is the earth. Good thing we live here!

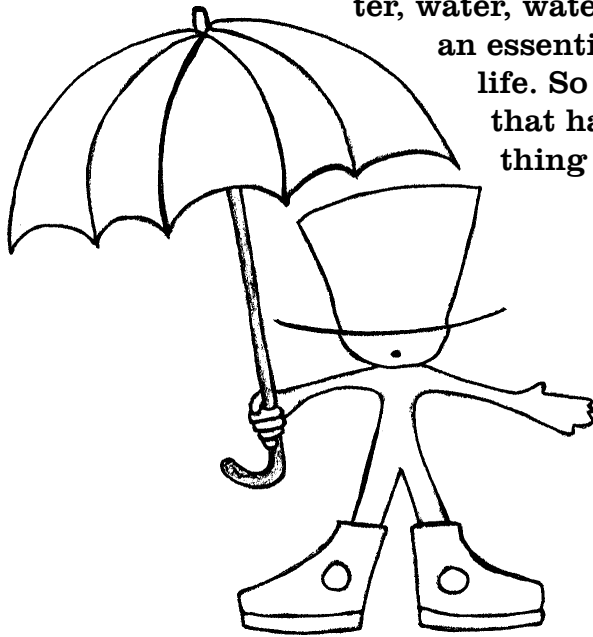

The Effect

You have some cards that represent all of the planets in our solar system. You shuffle them. You drop them into a paper bag. Then you say, "Which planet in our solar system has water and can support life?" You thump the bottom of a paper bag, and the earth card comes flying out. "That's right... only the earth."

What You Need

- paper bag
- magic marker
- piece of white poster board
- scissors

What You Need To Make

1. You'll need to make nine poster board cards. Cut these into 2 inch x 3 inch rectangles.
2. Now write the name of one planet on each card with the magic marker. Earth, Mars, Jupiter, Saturn, Uranus, Mercury, Venus, Neptune, Pluto. Leave the backside of the cards blank. (See illustration 1)

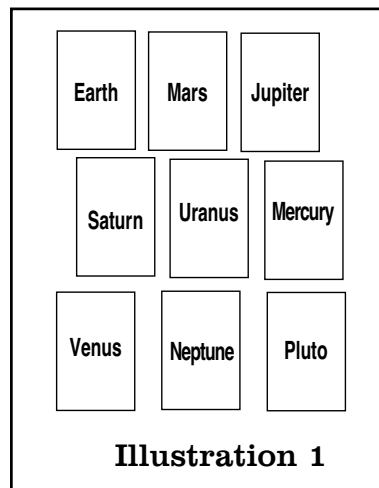

3. Take the paper bag and roll down the sides so the bag is approximately 7 inches tall from top to bottom. (See illustration 2)

Secret Set-Up

Stack the cards. Make sure the earth card is on the top of the stack. That's it.

Showtime

1. Show all of the cards face up.
2. Put them on the table face down and mix them around with your hands. Keep your eye on the top card. Don't lose it. (See illustration 3)
3. Say to your audience, "I'm going to mix these guys up."
4. Now stack the cards into a pile. The earth card should still be on top of the stack. Don't look at the faces of the cards.
5. Hold the bottom of the paper bag with palm of your left hand. (See illustration 4)
6. Put all the cards into the paper bag. While putting them in, slide the top card off with your thumb and first finger. (See illustration 5)
7. Set all of the cards except the top card (the earth card) on the bottom of the bag. Lean the earth card against the inside of the paper bag. (See illustration 6)
8. Pull your hand out of the bag.

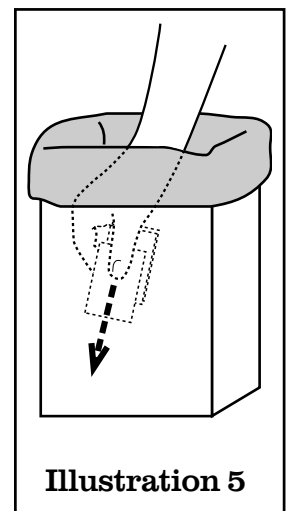
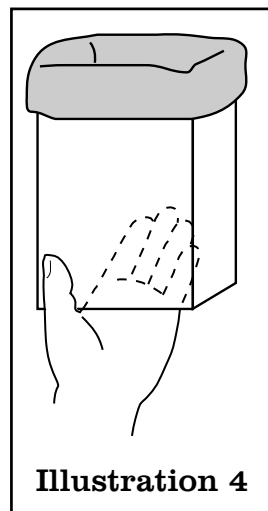
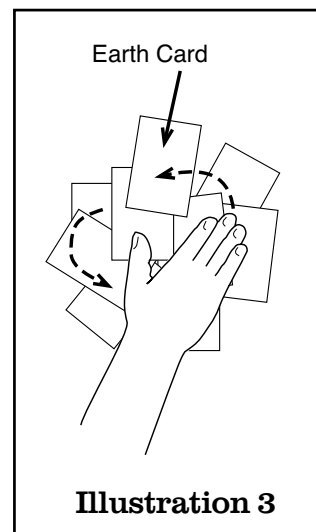
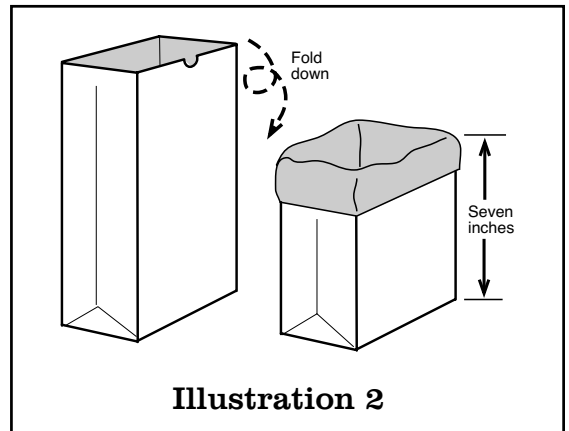

9. Ask your audience, "Which planet is the only one in the known universe that supports life and has water?"
10. Thump the bottom of the bag right below the earth card. It will come flying out of the paper bag as if by magic. (See illustration #7)
11. Pick it up and show everyone that the earth card has come leaping out. Say, "That's right. The only planet that can support life as we know it and has water is... The Earth."

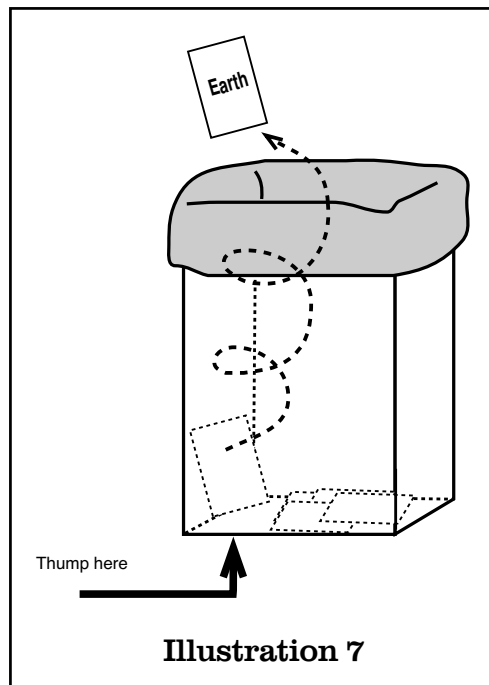
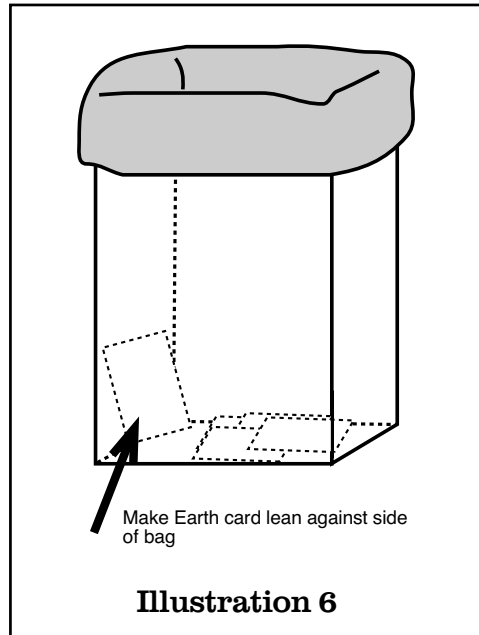

Carbon Creatures

As far as we know, all the living things in our solar system are carbon based. That means they are made of the elements carbon, hydrogen, oxygen, nitrogen, and a few others. Each element has a symbol that represents it.

C=carbon.
H=hydrogen,
O₂=oxygen,
N=nitrogen.

Here's a great trick that illustrates what living things are made of.



The Effect

Pieces of tissue paper combine to become a little tissue paper person.

What You Need

- piece of light colored (yellow, white, or pink) tissue paper
- two identical paper cups
- two pieces of green construction paper
- black magic marker
- pencil
- scissors
- glue
- table
- chair

What You Need To Make

1. Tear the top of cup #1 off about three quarters of the way up. (See illustration 1)



2. Tear the top of cup #2 off at exactly the same place. These two torn cups should look exactly alike.

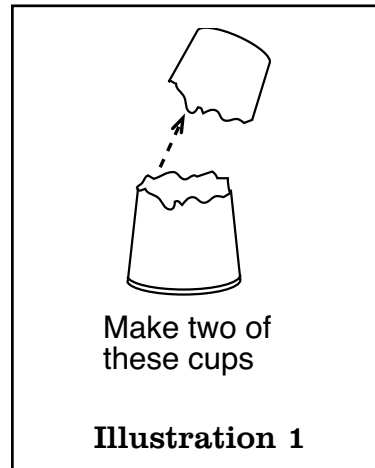

3. Place the rimmed edge of cup #1 on the first piece of construction paper. (See illustration 2)
4. With a pencil trace the rim of the cup.
5. Cut the construction paper circle out with your scissors. (See illustration 2)
6. Glue the paper circle to the rim of cup #1. (See illustration 3)
7. Cut a figure of a person out of the tissue paper. (See illustration #4) Make sure it is small enough to fit beneath the mouth of the cup.
8. Cut another piece of tissue paper into five small pieces. (About 1/2 inch by 1/2 inch)
9. Write the letter "C"...for carbon. "H"...for hydrogen. "O₂"...for oxygen. "N"...for nitrogen on each piece of paper. (See illustration 4)

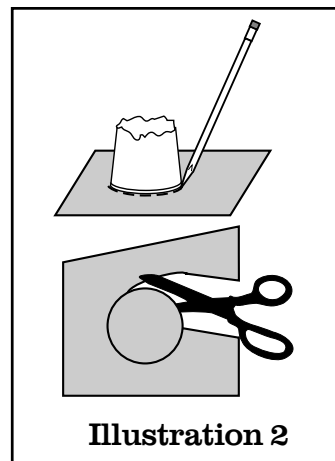

Illustration 2

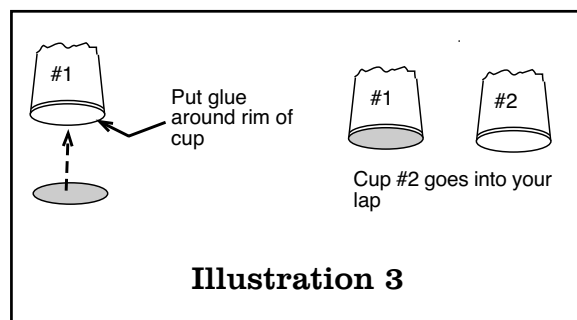

Illustration 3

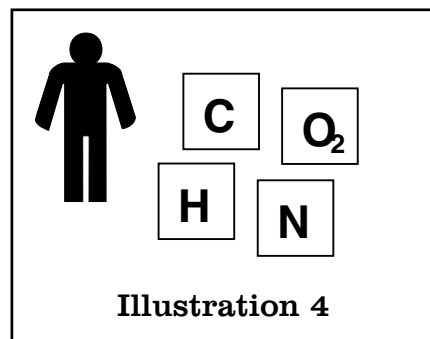

Illustration 4

Secret Set-Up

1. Set the sheet of construction paper on the table.
2. Set the tissue paper "person" in the middle of the construction paper.
3. Set cup #2 (rim side down) on top of the tissue paper person

in the middle of the construction paper.

4. Secretly put cup #1 in your lap.
5. Now you're ready to go.

Showtime

1. Ask someone from the audience to look into the top of the cup. Say, "What do you see?" They'll see nothing but the construction paper through the cup.
2. Have the person drop the small pieces of tissue paper into the top of the cup. (See illustration 5)
3. Now cover the top of the cup with your right hand. Blow magically on the cup. Say, "People are made of carbon, hydrogen, oxygen, nitrogen, and a few other elements."
4. Lift the cup off the construction paper and immediately drop it into your lap. This exposes the tissue paper person. It will look to your audience as if the pieces of tissue paper have been transformed into a tissue paper person.
5. Lift the second cup back up onto the table and show that it is empty.
6. Pick up the tissue paper person and make it dance around on the table.

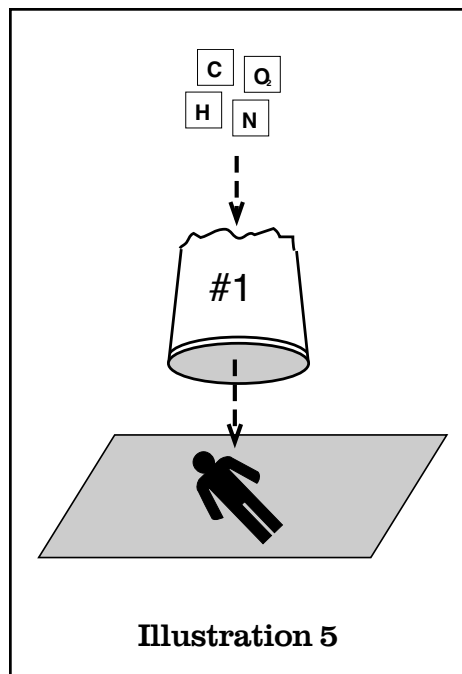

Renewable Resources

A tree is a renewable resource. A river is a renewable resource. Clean air is a renewable resource. Food is even a renewable resource. Bread, because it is made of wheat and can be grown, harvested, and then grown again, is a renewable resource. Any resource that can be used, yet doesn't reduce the availability for future generations, is a renewable resource. Remember... Renewable resources must be used no faster than they can be replaced. That's what keeps them renewable.

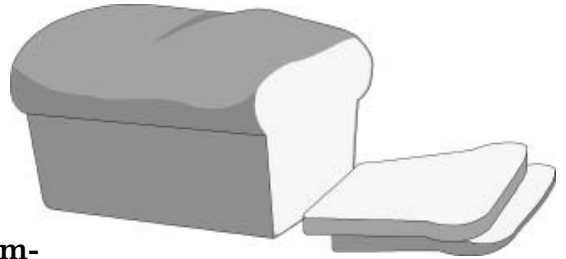

Air = Renewable Resource

Water = Renewable Resource

Food = Renewable Resource



The Effect

Three rolled up balls of bread are shown to the audience. Two bread balls are placed into a tea cup. The third ball is eaten. Magically a third ball appears in the cup to replace the discarded one.

What You Need

- coffee cup (a clean one)
- slice of fresh bread
- table

Secret Set-Up

1. Take a piece of bread and tear four small pieces off.
2. Roll each one of these pieces into four small balls. (See illustration 1)

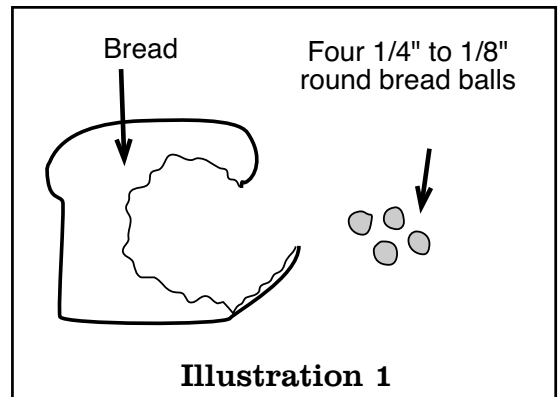

3. That's it. The real secret is that we're using four balls instead of three. The extra ball is always kept a secret.
4. Right before the show hide one of the bread balls between your right thumb, first finger and second finger. (See illustration 2) This is the secret fourth ball. No one should know it exists.
5. Put the other three balls in the cup, and you're ready to go.

Showtime

1. Pour the three balls out of your cup onto the table with your right hand. Say, "Renewable resources can be used, but they must not be used any faster than they can be replaced." Set the cup down.
2. Pick up one of the balls from the table with your right first finger and thumb. Show this bread ball and drop it back into the coffee cup. Say, "One."
3. Pick up the second bread ball and drop it and the hidden ball into the coffee cup. Say, "Two." (See illustration 3)
4. Pick up the third bread ball and put it into your mouth and eat it. Go ahead and swallow it. It's only bread. Say, "Bread is a renewable resource

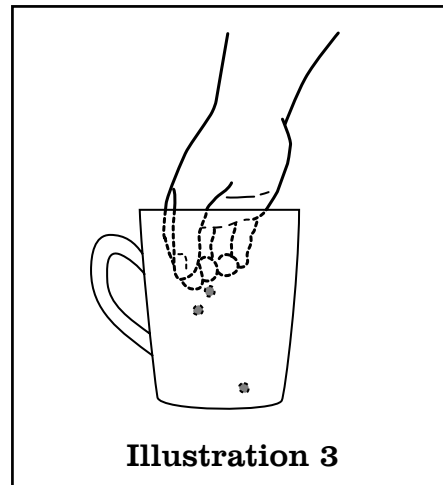
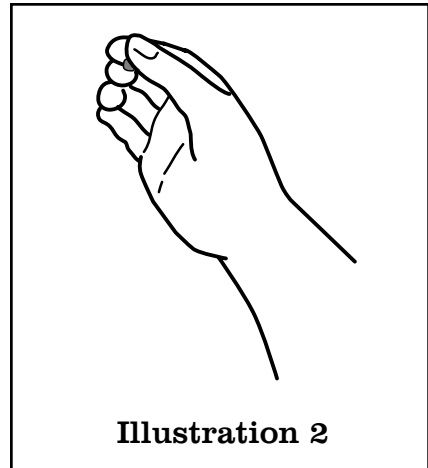

because we can use it and then grow more."

5. Pour out the three balls that are now in the cup. "Because it is a renewable resource, we can eat it, and still have more in the future."
6. Count the three balls on the table.
7. Congratulations! You're fabulous! Absolutely fabulous, darling!

Dinosaur Water

Water is continuously cycling around and around and around. The water that exists now is the same water that has always existed. Mother Nature simply cleans it up and uses it again. It is recycled over and over again. The same water that a dinosaur's body was made of millions of years ago, is the same water that may make up your cup of tea tomorrow. The same water that you flushed down the toilet last month is the same water that makes up an orange that you may eat today.

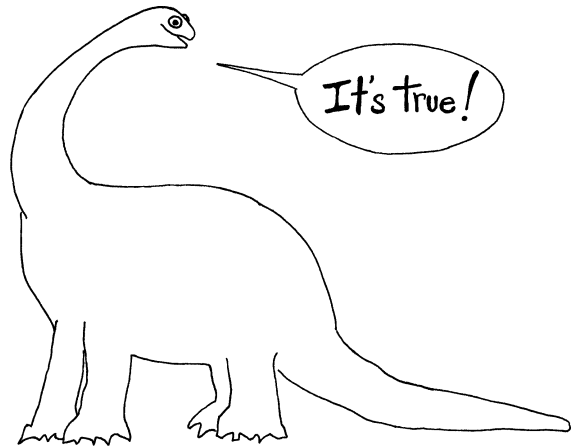

The Effect

Three volunteers from the audience sit around a card table. A blue ball (representing water) magically moves across the table.

What You Need

- secret assistant
- empty tea cup
- orange
- toy dinosaur
- blue ball (about the size of a racquet ball)
- roll of toilet paper
- glass of water
- spool of strong dark thread
- card table
- three chairs
- tablecloth
- two rings (each ring should be 1 & 1/2 inches across)

Secret Set-Up

1. Tie the ring to one end of the thread. This is a gimmick no one ever sees.
2. Set this ring in the middle of your card table. This is your starting position. (See illustration 1)
3. Run the thread across the table top away from your secret assistant's chair.

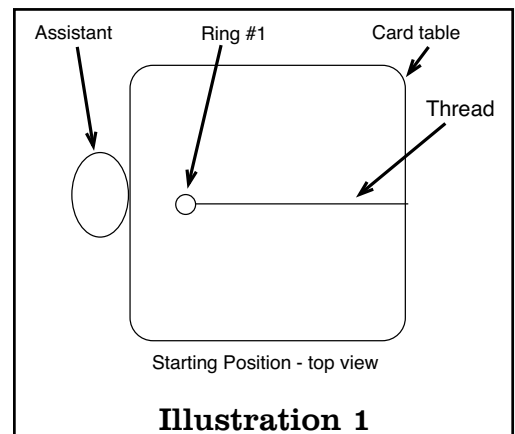
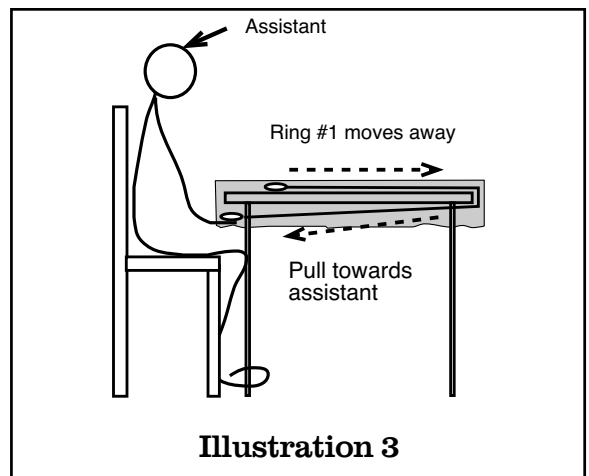
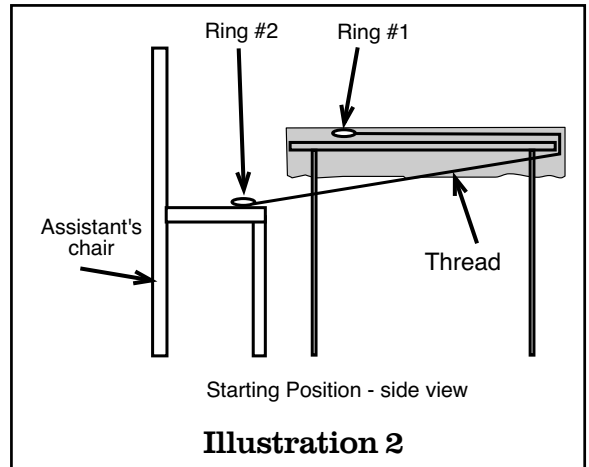

Illustration 1

4. Run the thread under the table until it can sit on your secret assistant's chair. Cut it off here. (See illustration 2)
5. Tie the second ring to the end of the thread and set it on your secret assistant's chair.
6. Put the tablecloth on the table. (It goes over the thread and ring gimmick.)
7. Have your secret assistant practice pulling the thread beneath the table without being detected. This will move the ring across the table away from him. (See illustration 3)
8. Set the ring back in starting position.
9. Set the props out on the table. (See illustration 4)
10. Now you're ready to go.



Showtime

1. Ask for three volunteers from the audience.
2. Select your secret assistant and two other people.
3. Have them sit down at the tablecloth covered table. Make sure your secret assistant sits in the correct chair.
4. Your secret assistant secretly grabs the ring/thread gimmick and holds on to it beneath the table.

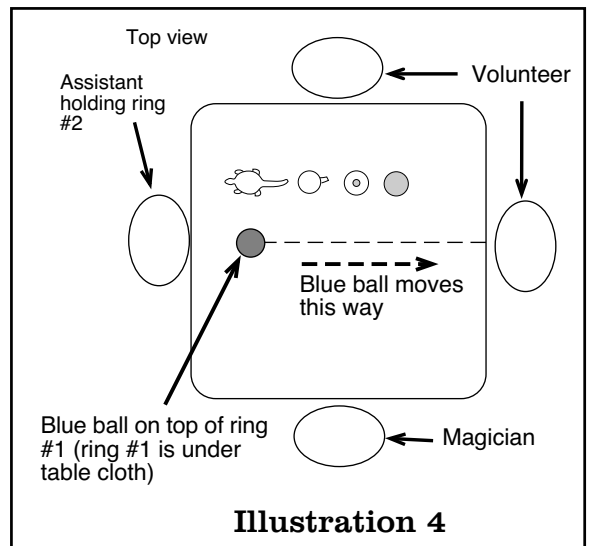

5. Ask your volunteers to put their hands in their laps. Your secret assistant does this too.

6. Pick up and show the dinosaur prop, the tea cup prop, the toilet paper prop, and the orange prop. Set them all back down on the table in a row. (See illustration 4)

7. Say, "Water molecules are recycled over and over again."

8. Show the blue ball. Set it on the ring gimmick.

9. Say, "Molecules of water continuously cycle through many life times. They can be a part of a dinosaur."

10. Wave your hand over the blue ball. Your secret helper pulls the string towards him until the balloon reaches the tea cup. (See illustration 5)

11. Say, "It can be part of your next cup of tea." Wave your hand over the tea cup. Your secret assistant pulls the string towards him and stops the blue ball at the toilet paper.

12. Say, "It can be a part of the water you flush down the toilet." Wave your hand over the tea cup. Your secret assistant stops the blue ball at the orange.

13. Say, "It can be part of the orange you eat next week." Have your secret assistant stop the blue ball at the orange.

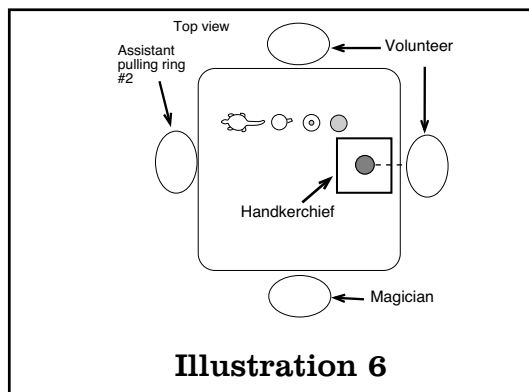
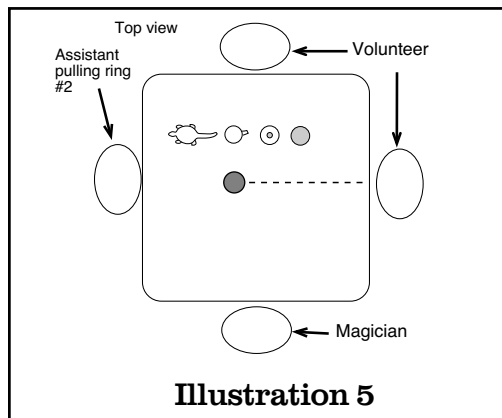

14. Say, "Or it can be a part of your body." Lay the handkerchief down on the table in the path of the blue ball. Have your secret assistant pull the string and roll it onto the hanky. The blue ball will roll easily up onto the hanky. (See illustration 6)

15. Lift the four corners of the hanky and pull the blue ball free from the table.

16. Say, "Water is magically recycled over and over again."

17. Take a bow.

18. Thank your volunteers.

Oil in Water Trick

Science is fascinating. We use it to understand how the environment works. We can also use it to clean up messes we've made in the environment. Take an oil spill for example. When oil is spilled in water it's really difficult to clean up because it spreads out across the top of the water very rapidly. It's dangerous because it can kill the plants and animals it touches. Once the mess has been made (it's better to not make the mess in the first place, of course) science can help in the clean-up. Microscopic (very very tiny) bugs that eat oil are used to help with the clean-up. The bugs are brought in to eat the oil. A little fertilizer is added to make the oil even more appetizing. The bugs chow down. The oil goes through the bugs' bodies and breaks down into harmless nutrients. This clean-up process is called bio-remediation. Here's a trick that uses nature to clean up spilled pepper.

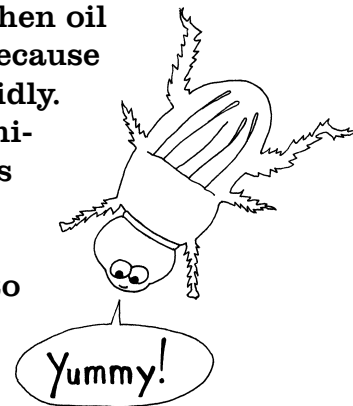

The Effect

Black pepper floating on the surface of a glass of water is ordered to move, and it does.

What You Need

- shaker of black pepper
- glass of water
- liquid dish washing soap
- your finger

Secret Set-Up

1. Fill the glass with water.
2. Secretly cover your left first finger with dish washing soap. (Any kind will do - it won't show. Hee, hee, hee! You're so sneaky.) (See illustration 1)

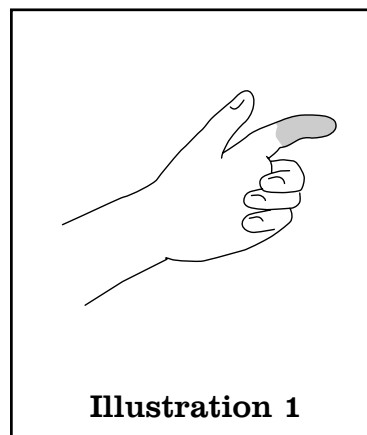

Illustration 1

3. Now you're ready to go.

Showtime

1. Show the glass of water to everyone.
2. Say, "This is magic pepper. It does exactly what I tell it."

Sprinkle some pepper into the water. (It will float on top.)
(See illustration 2)

3. Ask someone to very gently dip her first finger into the glass and keep it there. Say, "Pepper, don't move." (See illustration 3)
4. Tell your volunteer to pull her finger out. Nothing happens.
5. Now say, "Watch carefully. When I say 'move,' the pepper will race to the sides of the glass."
6. Say, "Move," and dip your left first finger into the water and the pepper will race to the sides. (See illustration 4)
7. Congratulations! You're magic!

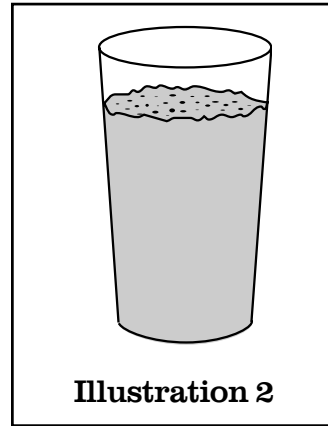

Illustration 2

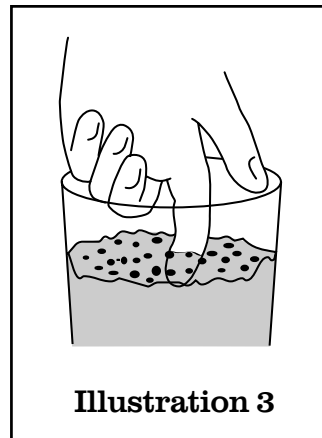

Illustration 3

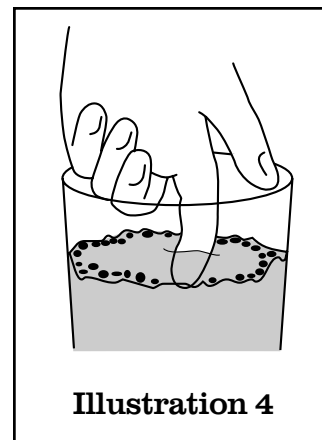

Illustration 4

Glossary

Atmosphere - The layer of gases that surround the Earth. Our planet's atmosphere contains many gases including nitrogen, oxygen, carbon dioxide, and ozone. This combination of gases is essential for life on Earth.

Aquifer - Any rock or sediment that is permeable enough to store and move water to wells and springs.

Biodiversity - The wide variety of different species found in a designated area.

Biosphere - The part of our planet that supports life. Bio means life. Sphere is a ball-like shaped object like our planet. All creatures that live on planet Earth live within the Biosphere. It stretches from the deepest oceans to the tallest mountains.

Carbon dioxide (CO₂) - A gas made of one carbon atom and two oxygen atoms. Trees and plants breathe in carbon dioxide and breathe out oxygen. Without plants to produce it, there would be no oxygen in our planet's atmosphere.

Chlorofluorocarbons (CFC's) - Chlorine-based compounds used commonly as aerosol propellants, as coolants in refrigerators and air conditioning, in fire extinguishers, in solvents, and in the production of insulating foam packaging. CFC's contribute to the destruction of the protective ozone layer in the stratosphere.

Clearcutting - Cutting all the trees in an area. Clearcutting can cause severe soil erosion, habitat loss, and water pollution.

Compost - Organic matter such as leaves, limbs, kitchen scraps (but no meat) and yard waste that has naturally biodegraded into a soil-like product rich in slow-release nutrients. It's excellent food for gardens.

Conservation - To save something. Any activity that is designed to save or use a resource wisely; may refer to land conservation, energy conservation, water conservation, or wildlife protection.

Consumers - Organisms that feed on producers, other consumers, and wastes of consumers.

Deforestation - Large scale removal of trees. This can occur through fires caused by lightning, fires caused by human carelessness, by severe floods, or by clear-cutting.

Deinking - A process in which some portion of the ink, filler, coating, and other extraneous (noncellulose) material is removed from printed and/or unprinted paper.

Disposables - Consumer products, items, and packaging used once or a few times and discarded.

Diversity - Different or not the same. There is a huge diversity of living things on the Earth. Scientists know of at least 2 million species and are discovering more everyday. Diversity insures a healthy, balanced, and strong ecosystem.

Ecosystem - A community of organisms that interact with each other and the physical environment.

Erosion - The process by which soil or other particles are carried away by water or wind.

Environment - Where a plant or animal lives and all the things that affect it there.

Environmentally friendly products - Products that do not have a negative impact on the environment. To be truly environmentally friendly these things must be considered: how is the product produced, how is it packaged, how is it used, how will it be disposed of.

Extinction - When all individuals of a species die. Recent extinctions include the passenger pigeon, dodo bird and prairie wolf.

Food chain - The relationship of plants and animals to each other through their shared need for energy and nutrients in an ecosystem. The simplest life forms, such as plankton and grass, are at the bottom of the food chain. They are in turn eaten by larger and more complex organisms. These organisms are in turn eaten by even larger and more complex organisms. People are at the top of the food chain.

Food web - The combination of all the food chains and other feeding relationships in an ecosystem.

Forest - Forests are complex systems of interrelated living and non-living things (trees, animals, soil, wind, insects, water, plants). Forests are home to plants, animals, and insects. They are the transformers of carbon dioxide (CO₂) into fresh air for us to breath, and they are the providers of wood and paper products for us to use. Tree farms are not forests. They consist of trees that are generally the same age and species, and they are clear-cut at the same time.

Green - The word and the color green have become a symbol for ecology and caring for the environment.

Greenhouse effect - When heat from the sun is released by the Earth and is trapped in the atmosphere by a blanket of gases. These gases keep the Earth from losing most of its heat. The greenhouse effect is a naturally occurring event. Some scientists believe that the effect is gradually being increased by man-made gases added to the atmosphere.

Groundwater - Water beneath the Earth's surface. Much of our drinking water comes from groundwater. Groundwater is within an aquifer.

Habitat - The place a given organism usually lives. The habitat is the home of a plant or animal. It's where the plant or animal can find food, water, shelter, and raise its young.

Hazardous waste - Waste material in a form and quantity which may pose a hazard to human health or the environment and, therefore, has been classified and regulated as a hazardous waste by an applicable regulatory agency.

Incineration - The process of burning garbage to reduce its volume. Toxic ingredients in incinerated materials remain in the form of toxic ash.

Indigenous - Plants, animals, or people that are native to a specific area.

Landfill - A place where waste material (garbage, refuse, or rubbish) is disposed of by being buried in the ground.

Leaching - The process of any material seeping, dissolving, and traveling through soil. The material is carried through the soil generally by rainwater. Man-made examples of leaching might include oil dumped on the ground, pesticides, or metals from mining. Natural examples of leaching could include rain reacting with organic material to acidify the water and create vast caves like Carlsbad Caverns, NM, or Mammoth Cave, KY.

Love - To actively care for, respect, and treat with value.

Nature - Everything on our planet is a part of nature. Nature provides everything we need to live. To insure that it will continue to provide for us, we must work with it, respect it, protect it, and love it.

Nutrients - The materials needed by an organism for energy, growth, maintenance, or tissue repair.

Organic matter - Anything that was once alive.

Organism - An individual, living creature.

Oxygen - The gas which makes up 21% of our atmosphere; it's created through the photosynthesis of plants.

Pesticide - A chemical designed to kill organisms considered to be undesirable.

Photosynthesis - When a plant uses sunlight, water and CO_2 to create its own food. Oxygen is released in the process.

Pollution - Any change of air, water, or land that can harm humans or other living organisms.

Post Consumer Waste - Recycled material that continues to operate in a closed recycling loop.

Precycling - The process of selecting products that are more easily recycled. (For example, you might buy white paper instead of colored paper or corrugated cardboard instead of plastic packaging.)

Recyclable - A product or material that can be reused or recycled.

Recycled - A product or material that is made of recycled material.

Reforestation - The replanting of trees in a cleared area.

Solar Energy - Solar means sun. Solar energy is the energy that comes to us from the sun. Almost all of the energy on earth comes either directly or indirectly from the sun. This includes fossil fuel (gas & oil) because the energy is merely stored in the fuel. It originally came from the sun.

Species - Organisms that can mate and produce offspring that are able to reproduce.

Spirit - The essential part of you that is not your body. It is your true self.

Steve Trash - Really cool Eco-Hero guy.

Sustainable - Operating within the limits of nature so that continued operation can occur without harm or depletion.

Tropical rain forest - A geographic area with a tight canopy of predominantly broad-leaf evergreen trees receiving at least 100cm of rain each year. Tropical rain forests contain very high species diversity.

Water cycle - The natural movement of water through the biosphere from the atmosphere to Earth and back again.

Young Eco-Hero - Someone who wants to peacefully “heal” the planet by respecting themselves, respecting other people, and respecting the environment. Maybe you’re one?

Well, I hope you enjoyed reading

The Magic of Ecology

If you want to make the world a better place, it starts with you.

Respect yourself. Respect others. Respect the environment.

Peace and Recyclage,

Steve Trash

You can visit me online at www.stevetrash.com

THE END

